

DIMENSIONS™

DC to AC Power Inverter/Charger

Pure Sine Wave Output

Owner's Manual

Base Model: 12LP15/12LPC15

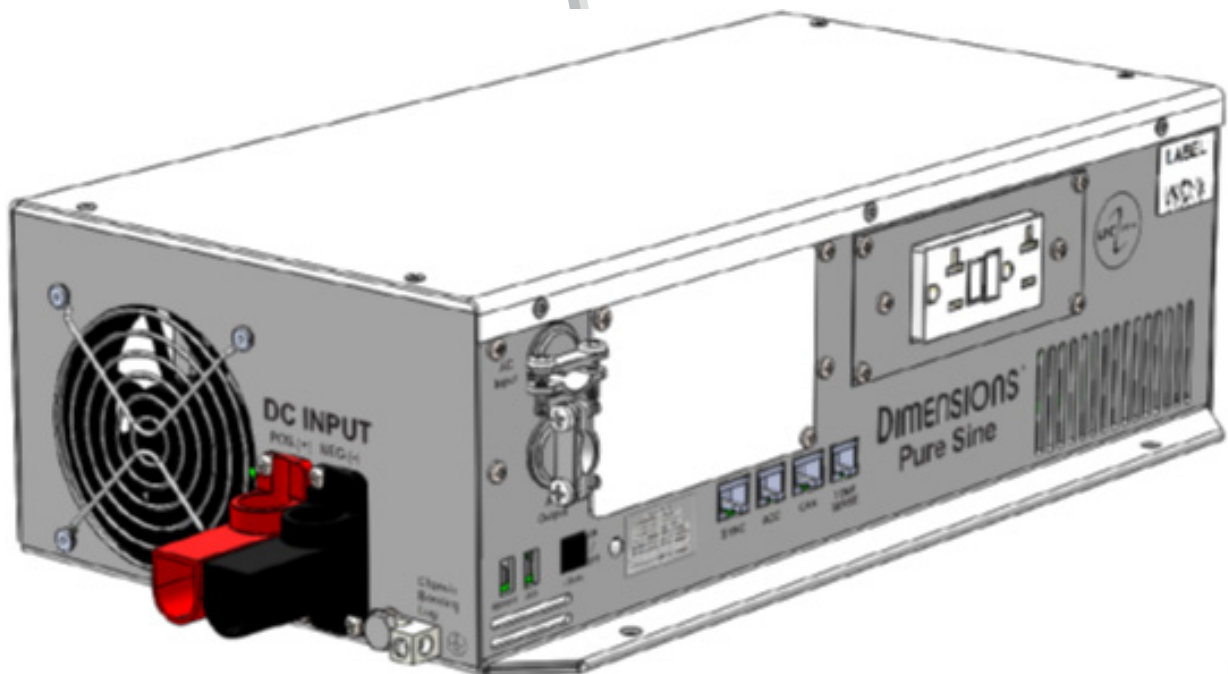

Sensata
Technologies

TABLE OF CONTENTS

Introduction	4
Contact Us	4
Important Safety Information	5
Specifications	7
Components	8
Design Features	9
Installation	10
Mount Inverter.....	10
DC Wire Gauge & Fusing.....	11
AC Input/Output Connections.....	14
Remote Inverter “On/Off” Switch.....	16
Operation	17
Inverter Power Mode	17
External Power Mode (LPC Only).....	18
GFCI.....	23
Configurations	24
Non-Volatile Memory (NVM) Setup Utility.....	24
Default Configurations	25
Switch Options.....	26
Low Battery Shutdown	26
Sleep Mode (Load Sense)	26
Shutdown Timer	27
Auxiliary Control.....	27
Battery Options (LPC Only).....	28
Branch Circuit Rating (LPC Only).....	28
AC Line Qualify Time (LPC Only).....	28
CAN Instance and Baud Rate.....	28
Troubleshooting	29
LED Status Chart - Normal Operation	29
Inverter Faults and Warnings	30
Charger Faults and Warnings.....	32
Troubleshooting Guide.....	33

TABLE OF CONTENTS CONTINUED

Appendix.....	34
Accessories & Replacement Parts	34
Inverter Model Options.....	34
CAN.....	35
Limited Warranty Terms & Conditions	37

INTRODUCTION

Thank you for purchasing a Dimensions™ inverter/charger from Sensata Technologies®! We think that you will find this product to be extremely reliable and easy to use.

Please read this manual completely before installing or operating the unit.

All information is subject to change without warning. Contact Sensata for the latest updates.

Contact Us

Sensata Technologies can be reached by phone or email if you need assistance with this product.

Phone: 1-800-553-6418 or 1-651-653-7000

Fax: 1-888-439-3565 or 1-651-653-7600

E-mail: inverterinfo@sensata.com

Website: <http://magnum-dimensions.com/>

Important Safety Information

Read this manual before installation. This manual contains important instructions pertaining to safety, installation, and operation.

Save this manual and keep it in a safe place.

Sensata Technologies is an ISO 9001:2015 Registered Company.

Sensata uses the following special notices to help prevent injury and/or damage to equipment:

Safety Symbols

- ▲ DANGER indicates an imminently hazardous situation which, if not avoided, will result in death or serious injury.
- ▲ WARNING indicates a potentially hazardous situation which, if not avoided, could result in death or serious injury.
- ▲ CAUTION indicates a potentially hazardous situation which, if not avoided, may result in minor or moderate injury.

CAUTION is used without the safety alert symbol indicates a potentially hazardous situation which, if not avoided, may result in property damage.

NOTE is used to notify of installation, operation, or maintenance information that is important but not hazard related.

Safety Listing



Power Inverter, E100666

Inverter Safety Instructions

- ▲ **WARNING:** Power inverters produce hazardous voltages. To avoid risk of harm or fire, the unit must be properly installed.
- ▲ **WARNING:** There are no user serviceable parts inside. Do not remove the cover.
- ▲ **WARNING:** Power inverters should not be mounted in a location that may be exposed to rain, spray, salt, or corrosive chemicals.
- ▲ **WARNING:** Power inverters should not be installed in a zero-clearance enclosure.
- ▲ **WARNING:** Damage to the power inverter will occur if correct polarity is not observed when installing the inverter's DC input cables.
- ▲ **WARNING:** Damage to the power inverter will occur if an external AC power source is applied to the inverter's AC hardwire output.
- ▲ **WARNING:** Power inverters contain a circuit breaker and capacitor that may produce a spark upon connection or during normal operation. Do not mount in a confined battery or gas compartment where toxic fuel vapor is present.
- ▲ **WARNING:** Be sure the power inverter is turned off and AC power is disconnected when batteries are being connected, disconnected, serviced, and replaced or personal injury and/or damage to the inverter could result.
- ▲ **WARNING:** Working near lead-acid batteries is dangerous. There is a risk of acid exposure.

Battery Safety Instructions

- ▲ **WARNING:** Batteries may vent explosive gases during operation.
- ▲ **WARNING:** There is risk of high current discharge from shorting a battery that can cause fire and explosion. Use insulated tools during installation.
- ▲ **WARNING:** Remove all rings, watches, jewelry, or other conductive items before working near the batteries.
- ▲ **WARNING:** Inspect the batteries at least once a year for cracks, leaks, or swelling. Follow the scheduled maintenance procedures from the battery manufacturer.
- ▲ **WARNING:** Dispose of the batteries according to local regulations. Do not incinerate batteries; there is risk of explosion.
- ▲ **WARNING:** A fuse must be installed between the battery and the inverter to protect against shorted cables.

Specifications

All ratings above assume 12.6 VDC nominal voltage, 25°C ambient temperature, and the inverter is mounted in free air. 12.6 VDC is to be measured at the inverter input terminals.

For use at ambient temperatures less than -20°C, use the hardwire connections. The GFCI may not properly operate at temps below -20°C.

At temperatures greater than 25°C, the inverter output is de-rated. See graph in “Operation” section of the manual.

LP units operate in inverter mode only. LPC units are able to operate in inverter mode and charge mode with bypass.

Input Voltage (VDC)	10.5 – 15.0
DC Surge Voltage (VDC)	Up to 24 VDC
Output Voltage (VAC)	120 +/- 5%
Output Frequency (Hz)	60 +/- .05%
THD	< 5% at 12.6 VDC and 1500W
Output Waveform	Pure Sine < 5% THD
Output Power (Watts Cont.)	1500
Output Current (AAC Cont.)	12.5
Input Current (ADC Cont.)	Up to 167 at 12.6 VDC
Input Current (ADC Cont.)	Up to 190 at 10.5 VDC
Peak Power (Watts)	3000
Peak Output (AAC)	25.0
Motor Starting Rating (h.p.)	1/2
Inverter Efficiency	Up to 80%
Charger Input Voltage (Vrms)	85 – 135 (LPC only)
Max Charger Output Current (ADC)	65 at 12.6 VDC (LPC Only)
Input Current Bypass (Arms)	20 (LPC Only)
Weight (lbs.)	30
Dimensions in. (L x W x H)	19.0” x 9.75” x 4.8” *
Operating Temperature	-40°C to 50°C (-40°F to 122°F) **
Agency Listings	UL458, E100666

Table 1 Specifications

* Length includes DC terminals and handle.

** At ambient temperatures above 50°C, the inverter/charger may fail to restart in the event it shuts down in an over temperature condition.

Components

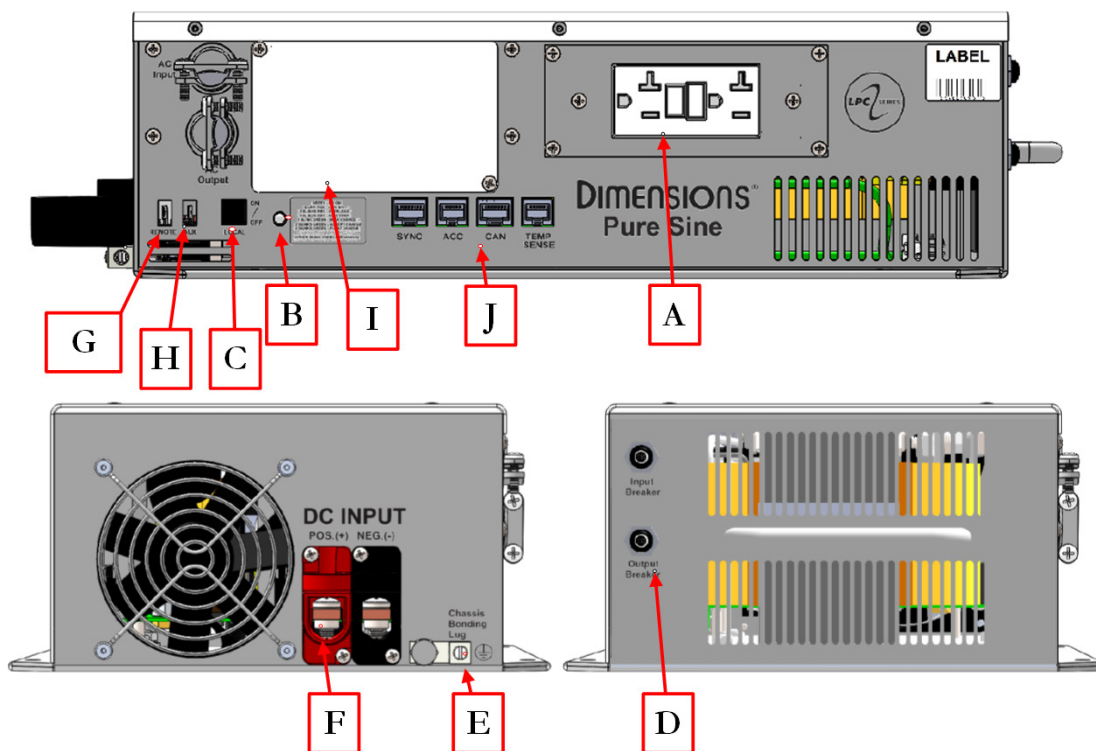

Figure 1 Components

- A. GFCI (not available with “H” suffix)
- B. Status LED
- C. Local On/Off
- D. AC Input and Output Breakers (no input breaker for inverter LP (inverter-only) models)
- E. Bonding Lug
- F. DC Input Connections
- G. Remote On/Off Wiring Tab
- H. AUX Wiring Tab
- I. AC Wiring Access Plate
- J. Various Ports

Design Features

- **GFCI:** Provides 120 VAC output. Only replace with an approved GFCI.
- **Status LED:** This LED will show inverter operation mode and troubleshooting information. See the table in the troubleshooting section at the rear of the manual for further operation mode descriptions.
- **Local On/Off:** This switch turns the inverter on or off. Switch inoperable for “HR” and “R” configurations.
- **AC Input and Output Breakers:** Protects the inverter from output short circuits and overloads. The 12LPC15 (inverter/charger) uses 20 A input and 15 A output breakers.
- **Bonding Lug:** Connects to the system ground.
- **DC Input Connections:** Connects to the battery bank.
- **Remote On/Off Wiring Tab:** Terminal is used to wire a customer supplied remote snap “On/Off” switch. Apply battery voltage to tab to turn on inverter.
- **AUX Wiring Tab:** Terminal is used to enable internal housekeeping power only. Apply battery voltage to enable. Does not turn on inverter output.
- **AC Wiring Access Plate:** Provides wiring and inspection access to AC output terminals inside the AC wiring box. To be closed during operations.
- **Various Ports:** “CAN” is used for connection of a CAN interface. “Temp Sense” is used for connection a battery temperature sensor (BTS) that is sold separately. “ACC” is used for a remote switch that is sold separately. The “Sync” port may be plugged with an empty connector because it is currently not used. The “Temp Sense” port may also be plugged with an empty connector on LP models.
- **Unit Protection:** Automatic inverter short circuit/overload protection, automatic over temperature shutdown, and AC output circuit breaker.
- **Battery Protection:** Automatic low battery shutdown with an in-rush delay. Other low battery settings may be configured with the NVM Setup Utility.
- **Shutdown Timer:** Shutdown timer helps preserve battery life over long periods of time. When enabled, the timer will shut the inverter off in 30 or 60 minutes regardless of load.
- **Load Sense:** Inverter output will shut off if no load is connected. The inverter will turn back on when it detects that a load has been connected.

Contact the factory for updated information or for other voltage, current ratings, and battery configurations that may be available.

INSTALLATION

Mount Inverter

- ▲ **WARNING:** Power inverters produce hazardous voltages. To avoid risk of harm or fire, the unit must be properly installed.
- ▲ **WARNING:** Power inverters should not be mounted in a location that may be exposed to rain or spray.
- ▲ **WARNING:** Power inverters should not be installed in a zero-clearance enclosure.
- ▲ **WARNING:** Power inverters contain a circuit breaker and capacitor that may produce a spark upon connection or during normal operation. Do not mount in a confined battery or gas compartment.

Installation Tools

- Wire Termination Crimper
- Cable-Ties
- Drill
- #2 Phillips Screw Driver (with a magnetic end)
- Slotted Screw Driver
- Tape Measure
- Wire Cutters
- Needle Nose Pliers
- Wire Strippers

Inverter Mounting Recommendations

NOTE: The inverter mounting location should provide adequate ventilation and clearance to maintain room temperature during operation. At least 1/2" of clearance is required on all sides except the bottom.

1. Locate a suitable, secure mounting surface as close to the batteries as possible without being in the same compartment.
2. Mount the inverter using four 1/4-20 steel bolts, flat and lock washers, and nuts. The length of the bolts should be equal to the thickness of the mounting surface plus 3/4".

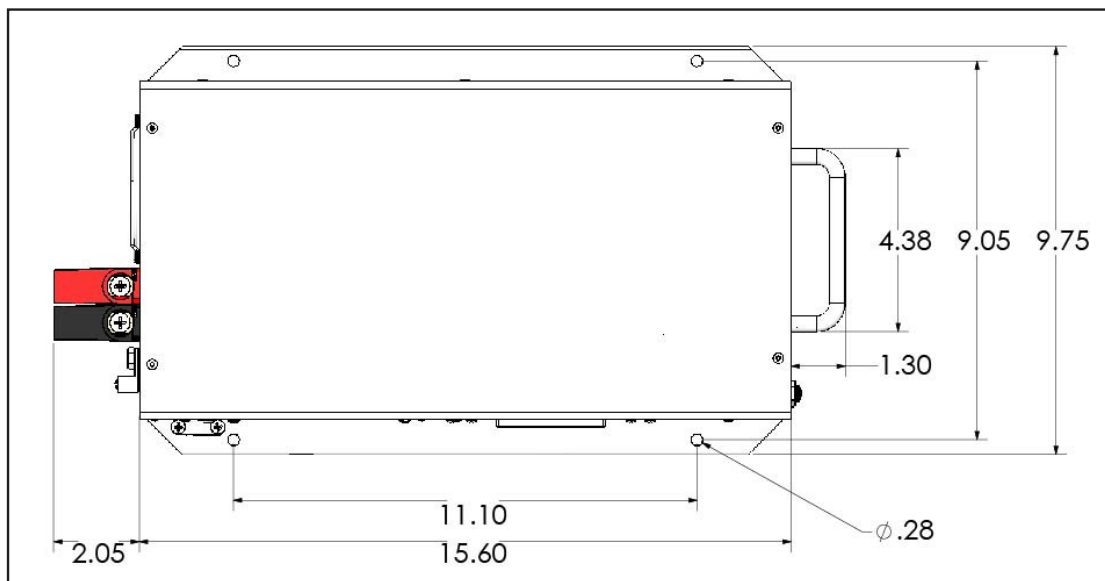

Figure 2 Mounting for All Models (Inches)

DC Wire Gauge & Fusing

▲ WARNING: Damage to the power inverter will occur if correct polarity is not observed when installing the inverter’s DC input cables.

Inverter Cable

Wiring should meet all local codes and standards and be performed by qualified personnel such as a licensed electrician.

An inverter cable kit (positive cable, negative cable, and proper fuse) is needed to connect the inverter to a battery bank. An inverter cable kit designed to SAE guidelines can be purchased directly from Sensata – call for options.

Min. Cable and Max. Fusing Guide for 3% Voltage Drop at 100% Output

Inverter Model	Full Load (ADC)	Inverter to Battery Est. Cable Length in Feet	
		Up to 15 feet @ 25°C (77°F)	
12LP15/12LPC15	190 ADC 100% Duty (at 10.5 VDC)	1/0 AWG, 350 A Fuse	
12LP15/12LPC15	190 ADC 50% Duty (at 10.5 VDC)	1/0 AWG, 350 A Fuse	

Installation

Table 2 Cable Sizing

NOTE: Using a smaller cable may cause a low battery or high temperature fault.

NOTE: 100% duty rating assumes the inverter is continuously operating at its full rated output power for at least an hour. The 50% duty rating assumes that the inverter is operating at its full rated output power for up to 15 minutes and then operating with a load less than 25% of its full rating for at least 15 minutes before returning to full power and repeating. Alternatively, the inverter can also continuously operate at 50% of its rated output power. Values in the provided table assume the inverter is operating in an ambient temperature of 25°C (77°F). For higher ambient temperatures, additional derating may be required (i.e. may need to use a larger cable size).

DC Wire Gauge & Fusing Continued

Make an Inverter Cable Kit

1. Use 1/0 AWG stranded copper cables in all cases.

NOTE: The maximum recommended length of the inverter cable is 15 ft, and the cable must be fused within 18 inches of the positive (+) terminal of the battery.

2. Use SGX cross-linked polyurethane insulation type that complies with the high temperature insulation requirements (125°C.) of SAE J-1127 and vehicle manufacturer requirements. Reference Table 2. For 1/4" ring lugs, use JST 38-S6.
3. Torque the DC connections on the inverter to 50-60 lbf·in.
4. Torque the inverter bonding lug to 45 lbf·in for 6 AWG or 40 lbf·in for 8 AWG.

NOTE: It is useful to use a needle nose pliers to help insert or remove the 1/4x20 screw and toothed washer.

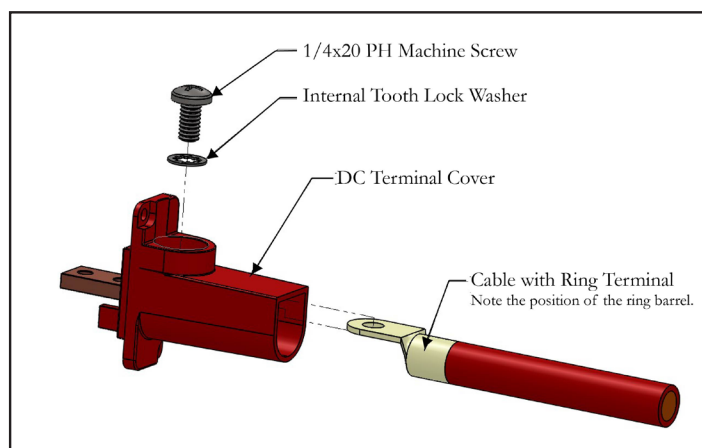

Figure 3 Proper Installation of Cable into DC Terminal Cover

DC Wire Gauge & Fusing Continued

Typical Cable Connection Procedure

NOTE: Refer to Figure 4 for a typical DC wiring diagram. See Table 2 for proper cable sizes.

1. Remove the fuse from the fuse holder.
2. Connect the inverter's bonding lug to ground of the vehicle chassis.
3. Connect the ring terminated end of the black inverter cable set directly to the negative (-) side of the battery bank at a negative battery post.
4. Connect the fuse holder to the positive (+) side of the battery bank.
5. Connect the ring terminated end of the red inverter cable set directly to the fuse holder.
6. Install the fuse in the fuse holder. A typical one-time spark will occur when this final connection is made.
7. Install the fuse holder cover.

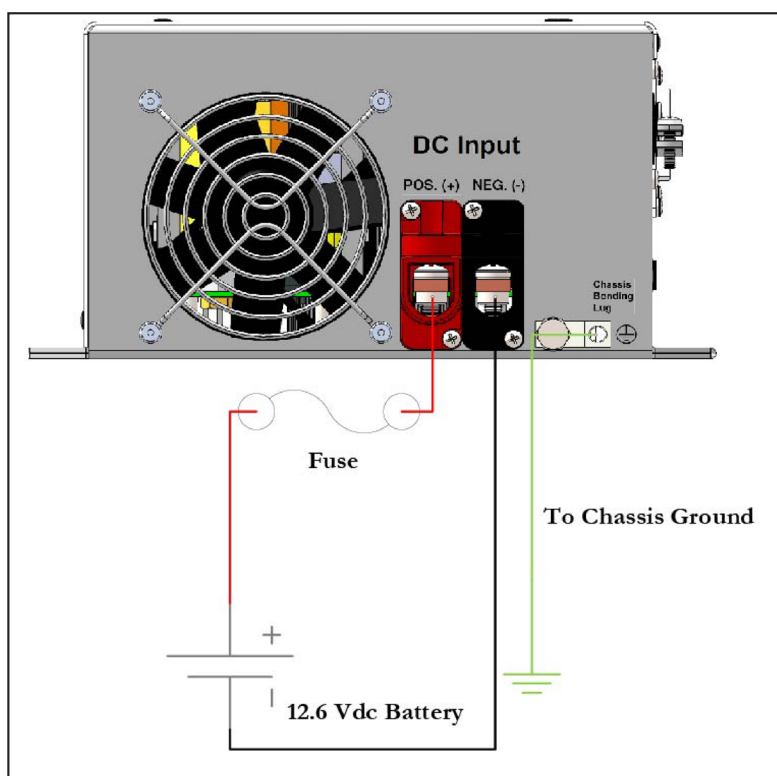

Figure 4 Typical DC Wiring Diagram

Installation

AC Input/Output Connections

- ▲ **WARNING:** Damage to the power inverter will occur if an external AC power source is applied to the inverter's AC hardwire output.
- ▲ **WARNING:** Do not directly connect another source of AC power to the AC output of the inverter. This will result in damage not covered under warranty.

GFCI

A 20 A GFCI is installed into the side of the inverter, except for hardwire-only versions ("H" suffix) where the GFCI is omitted. The rated output of the inverter is 12.5 A. If a 20 A load is applied to the GFCI, the 15 AAC output breaker installed on a 12LPC15 will eventually trip. The 12LPC15 allows for 20 A of bypass current. If 20 A of load is connected to the inverter or inverter/charger while in inverter mode, the inverter will shut down in overload.

Hardwire Interface

1. Remove the cover for hardwire AC wiring.
2. Insert the AC input and output wiring through the AC output cable clamps to protect the wires from the metal edge of the hole.
3. Connect the AC wiring to the provided internal terminal blocks. Check that the AC input wiring is connected to the AC input terminal blocks and the AC output wiring is connected to the AC output terminal blocks. The 12LPC15 should use 14 AWG minimum for the AC output. The AC terminal block will accept 14-8 AWG wire.
4. Torque the AC terminal blocks to 10 lbf·in.
5. Connect the hot wires to the black terminal, the neutral to the white terminal, and the ground to the green terminal.

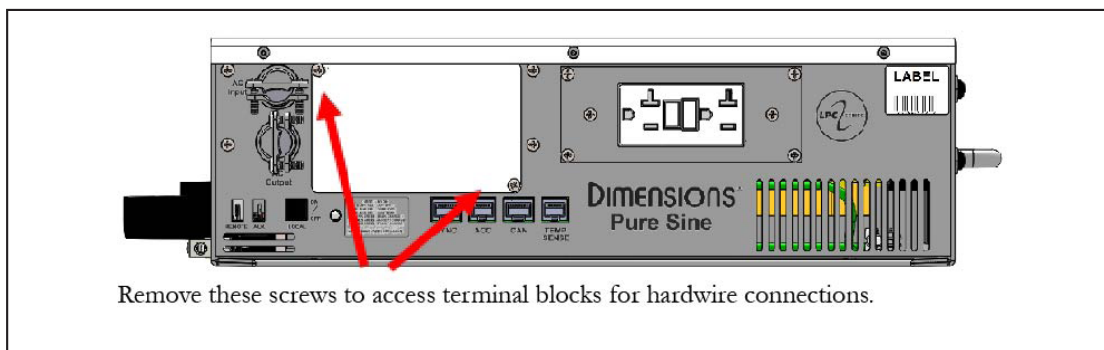

Figure 5 Hardwire Access

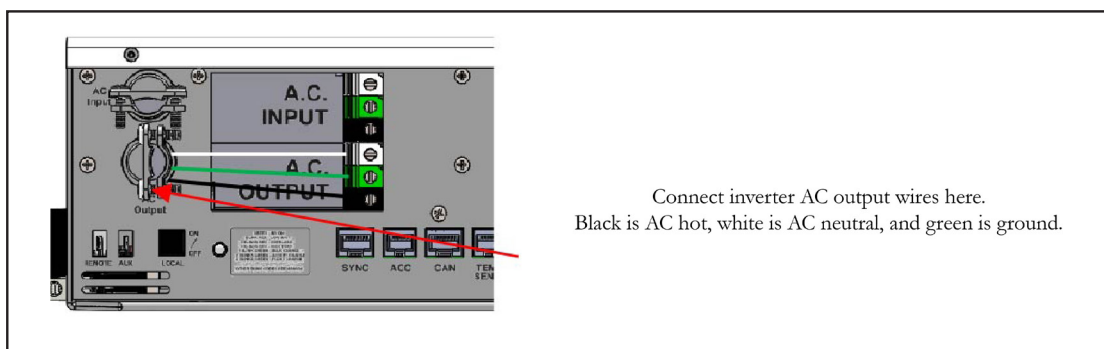

Figure 6 AC Inverter Output Connections

AC Input/Output Connections Continued

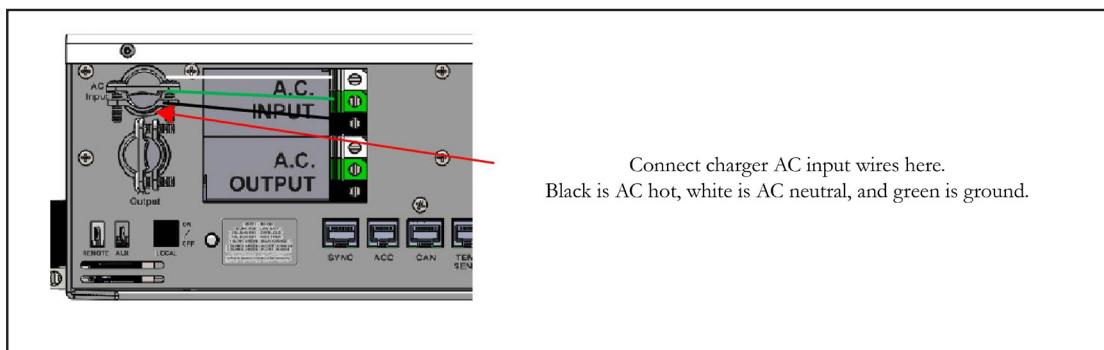

Figure 7 AC Input for Charger/Bypass

NOTE: The AC input should be protected by a 20 A branch rated breaker external to the inverter/charger.

NOTE: The AC output should be protected by a branch rated breaker external to the inverter if required to comply with the National Electric Code, NFPA 70, or the Canadian Electrical Code, C22.1.

NOTE: Connecting the AC inverter input to a GFCI protected outlet may cause some interference with the inverter's GFCI.

Remote Inverter “On/Off” Switch

Remote Inverter “On/Off” Switch Installation – Customer Supplied

For non “-R” suffix versions, a momentary switch must be used. In non-remote only mode, the momentary switch will toggle the inverter state between on and off, or standby and off while in charge mode. The remote switch may be customer supplied or ordered separately from the factory.

For remote only “-R” suffix versions, a snap switch must be used. If a snap switch is used in place of a momentary switch, the inverter may not correctly respond. In remote-only mode, the snap switch will turn the inverter on and off when in inverter mode. When in charger mode, it will switch the inverter state between off and standby.

1. Mount the remote switch in a convenient location.
2. Using 18 AWG wire and an insulated ¼” female faston, wire between the “Remote On/Off” connection on the left side of the inverter.
3. Wire from the remaining connection on the remote switch to the battery positive (+) terminal.
4. Install a 5 A in-line fuse in series within 18 inches from the positive (+) terminal of the battery.

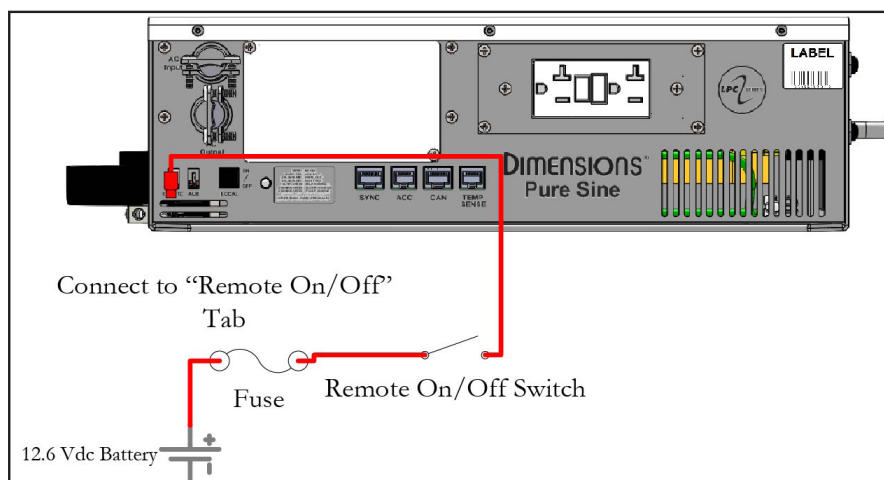

Figure 8 12LPC15R with Snap Switch

OPERATION

Once the inverter has been fully installed, wired, and DC power has been applied, the inverter is ready to turn on. The status LED beneath the AC wiring box on the left side of the inverter shows the current state of the inverter.

Inverter Power Mode

Usage: Any 120 VAC, 60 Hz single phase product within the inverter’s power rating.

The inverter can be turned on by using the local or remote switch. When the inverter is on, the local status LED will be a constant green. When the local “On/Off” switch is enabled in assemblies without the “R” suffix, any switch may turn the inverter on or off. When using the local switch, a momentary remote switch must be used. With the remote-only inverter, only the remote snap switch will turn on the inverter. The local “On/Off” switch will be inactive. The function of the switch will depend on the mode of the unit and if the AUX tab is enabled and being used.

The inverter front status LED will be green while the inverter is on. The AC power produced by the inverter comes from the energy stored in the battery bank through an electronic inversion process. A transformer, a Metal Oxide Silicon Field Effect Transistors (MOSFET), a filter capacitor, and a microprocessor are used to generate clean AC power.

The inverter will operate at DC input voltages ranging from 10.5 VDC to 16 VDC. If the inverter’s input voltage exceeds 16 VDC, the inverter may stop operating. The inverter can tolerate up to 24 VDC for 5 minutes; over 5 minutes will cause a shut down. Input voltages above 24 VDC will result in an immediate shutdown. The inverter will restart when the input voltage drops below 16 VDC. When the input voltage drops to the low battery voltage, the inverter will stop operating. When the lead-acid battery bank voltage drops to 10.5 volts, the battery is fully discharged.

The inverter output needs to be de-rated as the ambient temperature surrounding it increases. See Figure 9 for operation at 12.6 VDC.

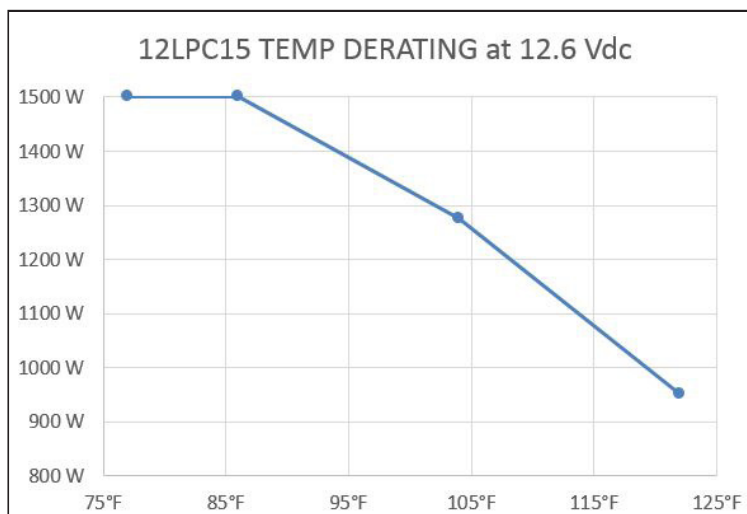

Figure 9 Inverter Output Temp Derating

External Power Mode (LPC Only)

Battery Charger

The LED display panel will show charger mode and the status LED located on the side of the inverter will blink green to indicate the charging process mode. See the LED Status Chart for additional blink codes.

NOTE: The battery charger requires about 8 VDC to be present at the DC output before the charger will operate.

The battery charger will engage automatically and independently of the inverter on/off status. The three-step charging process modes are bulk, accept, and float.

Bulk

The charger will output the maximum rated current to the battery until the battery voltage (as measured at the charger DC terminals) reaches the maximum voltage threshold or the constant current timer expires.

Accept

The charger will output at the rated voltage until the output current reaches nearly zero or the constant voltage time expires.

Float

The charger will output current and voltage at the minimum duty cycle until the voltage drops below a threshold.

External Power Mode (LPC Only) Continued

Battery Charger Continued

Battery Type		AGM	GEL	Wet
Bulk Charge Phase				
Bulk	Bulk charge current limit	SEE SPEC		
	Bulk phase terminates	1. When battery voltage reaches the accept voltage		
Accept Charge Phase				
Accept	Accept charge voltage @ 77°F/25°C	14.3 VDC	13.7 VDC	14.6 VDC
	Accept voltage temp compensated	5mv/cell/°C		
	Maximum accept voltage at low temps	15.0 VDC @ 4°C	14.5 VDC @ -6°C	15.0 VDC @ 10°C
	Accept phase terminates	1. When charge current is reduced. 2. When the accept timeout is reached.		
	Accept phase timeout	6 hours (may be configured through CAN)		
Float Charge Phase				
Float	Float voltage @77°F/25°C	13.4 VDC	13.4 VDC	13.2 VDC
	Float voltage temp comp	5mv/cell/°C		
Condition (Equalization) Phase				
Condition	Condition voltage @ 77°F/25°C	N/A	N/A	15.5 VDC
	Condition voltage temp compensation	N/A	N/A	30.24mV/cell/°C
	Condition duration	N/A	N/A	4 hours
	Condition frequency	N/A	N/A	Manual Control
Battery Temperature				
Battery Temp	Charger Warm Battery: output switches to compensated float from bulk/accept/off (hot)	>122F/50°C <140F/60°C		
	Charger High Battery Temp: output to off	>140F/60°C		
	Charger resumes in previous mode: bulk/accept/float	<112F/45°C		

Operation

Table 3 Three-Step Charger Recipe with BTS Reference

External Power Mode (LPC Only) Continued

Charger Battery Temperature Sensor (BTS)

The BTS measures the battery temperature and automatically adjusts the charger output voltage for the fastest and safest charge.

NOTE: If the BTS cable is not connected, the battery charger will not function. The charger will output about 8 VDC if the battery voltage has been removed after the charger starts.

When batteries are cold, their chemical reaction is slowed so they will not charge as easily. A charge voltage optimized for room temperature will not charge the battery at low temperatures. The BTS cable allows the charger to increase the charge voltage for optimum charging at low temperatures.

When batteries are hot, their chemical reaction is accelerated and they absorb energy too quickly. A charge voltage optimized for room temperature will tend to overcharge the batteries and cause gassing. The BTS will cause the charger to decrease the charge voltage to a safe level.

The charger will switch to a “warm battery” mode in which the charger will only provide a float voltage when the batteries reaches 122°F/50°C to 140°F/60°C. If the battery temperature continues to rise over 140°F/60°C, the charger will shut off. The charger will resume charging in the “warm battery” mode when the battery cools to 131°F/55°C. The charger will resume normal charging when the battery cools to 113°F/45°C.

Install the Battery Temperature Sensor

1. Connect the lug end of the temperature compensation cable to the negative post of the battery.
2. Insert the sensor plug to the appropriate mating connector located at the side of the inverter labeled “Temp Sense.” BTS cable is part# ME-BTS-XX (XX=length in feet - 6, 8, 15, 25, 40).

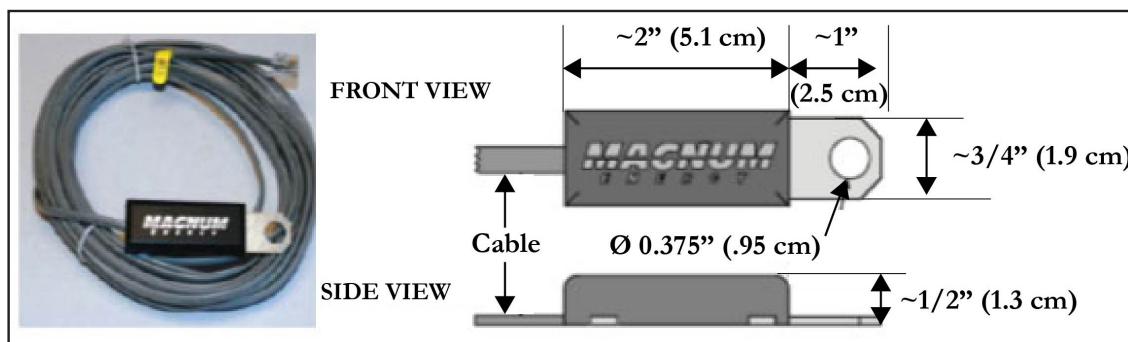

Figure 10 BTS

External Power Mode (LPC Only) Continued

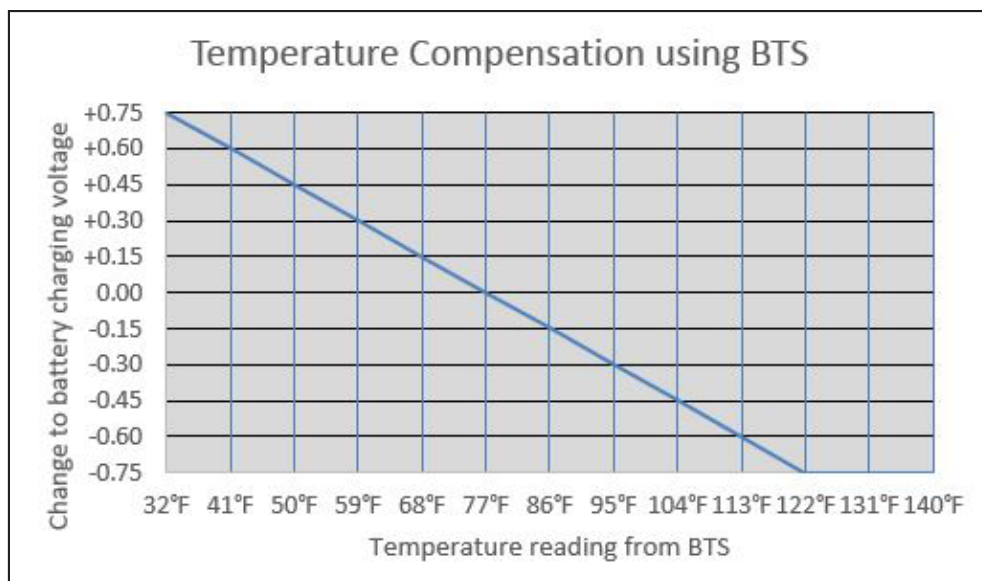

Figure 11 Charger Voltage Adjustment

Load Management

Incoming AC power is shared between the AC loads and the charger. The AC loads are given priority meaning that the charger will reduce its output with large AC loads. This feature controls the total amperage draw of the system so the utility service circuit breaker is not tripped. The load management feature will return the charger to full output when the AC loads are removed or reduced.

Operation

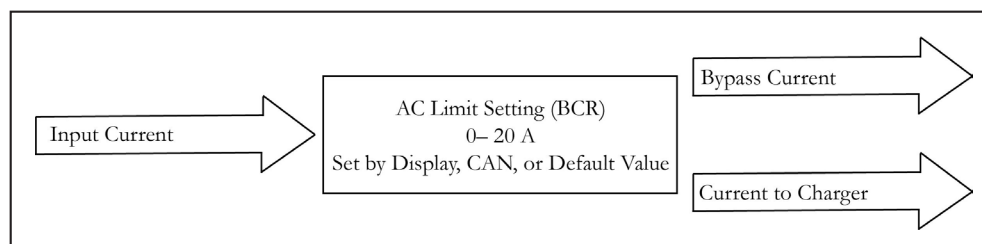

Figure 12 Load Management

External Power Mode (LPC Only) Continued

Load Management Continued

The charger splits the input current to the charger and to the AC output. The charger will limit the amount of current flowing to battery based on the AC current limit setting. If the total input current exceeds the limit setting, the charge current will be reduced until the limit is met. If the bypass current exceeds the limit setting, the charger will not output current to the battery. The default AC current limit is set by the factory to 15 A.

NOTE: Dynamic external loads may cause variations in the charge rate. The charger may reset if the dynamic load causes the input AC waveform to become temporarily disqualified.

Equalization

Available only for wet lead-acid batteries, this function overcharges the battery in a controlled way to remove sulphate buildup from the battery's internal plates. Consult your battery manufacturer on how frequently the equalization process should be carried out. Equalization can only be initiated with a RV-C CAN command. The process will not start until a full charge cycle has been completed.

Monitor

In this mode, the charger stops charging at the end of a charge cycle. The inverter monitors battery voltage and restarts a charge cycle if necessary.

NOTE: When in charge mode, the charger may not be able to charge at its full capacity if AC power is being used in bypass mode.

NOTE: The charger is capable of charging AGM, GEL, or wet lead-acid cell batteries. Selection of battery type must be done when ordering the inverter from the factory. The battery type may also be set with the NVM Setup Utility or via RV-C CAN. Contact the factory for further details on RV-C CAN.

Bypass

The loads attached to the inverter output will directly operate from the external AC power line independently of the inverter on/off status. If the inverter is left on (standby mode), the built-in bypass relay will automatically cycle back and forth between inverter and external power modes depending on the availability of the external AC power line.

NOTE: If the AC load is short-circuited while in bypass mode, the inverter/charger may experience an internal fault.

GFCI

A GFCI measures the amount of AC current into the GFCI line side “hot” and “neutral” terminals. Both terminals should measure the same amount of current under normal conditions. Any difference in current is considered the leakage current. If the leakage current is greater than 5mA, the GFCI will trip. A tripped GFCI suggests that there has been a breakdown in the electrical insulation of a connected unit. This can result in a safety hazard for the user. The breakdown could have been caused by broken wire insulation with the live wire contacting the ground conductor, water in contact with a live conductor, or any other inadvertent electrical path to ground. The inverter needs to be on or bypass power must be applied to reset a tripped GFCI.

When installed with a Leviton GFNT2 GFCI, the status LED will operate according to Table 4.

GFCI Status LED

LED Color & State	Condition	Action Required
Green — Constant On	GFCI is powered from the line side and operating correctly	None
Red — Constant On	Fault found during normal operation	Press “Test” to trip the GFCI. If it fails to reset after pressing “Reset,” the GFCI will need to be replaced.
Red — Blinking	Fault found during self-test	Press “Test” to trip the GFCI. If it fails to reset after pressing “Reset,” the GFCI will need to be replaced.

Table 4 GFCI Status LED

Operation

The GFCI installed in this inverter is compliant with the latest requirements for GFCIs per UL 943. This includes automatic self-testing and line-load reversal.

Self-Testing

The GFCI will periodically test the ground fault detection circuit in the background. If the test determines that there is a problem with the detection circuit, the GFCI will trip and/or notify the user visually with the status LED. The GFCI will perform a self-test when AC power is first applied. The LED will blink red before turning green.

Line-Load Reversal

If the line and load terminals are wired backwards, the GFCI will not reset and power will not be available until the wiring has been corrected.

NOTE: Depending on the GFCI model that is used, the line and load terminals on the rear may not be in the same position. The user must verify the GFCI markings just the to ensure proper connection.

NOTE: Replace the GFCI outlet with only the exact replacement part unless instructed to do otherwise by the factory. Other types may fail to properly operate when connected to this unit. Refer to Table 13 for replacement options.

CONFIGURATIONS

Non-Volatile Memory (NVM) Setup Utility

The inverter/charger settings may be adjusted with a NVM Setup Utility kit which is sold separately. The kit consists of a Kvaser® CAN interface which connects to a USB port on a laptop, a DB9 to RJ45 adapter, a terminating resistor, and a Windows PC program that can be installed on a x32 or x64 machine.

After the software has been properly installed, the Kvaser device may be plugged into the computer. The first time the Kvaser is connected, the computer may need to download the appropriate Kvaser drivers from the Kvaser website. Once the Kvaser device is ready to be used, the terminating resistor and DB9 to RJ45 adapter may be connected to the inverter CAN port.

Once the inverter is turned on, the NVM Setup Utility may be opened on the laptop. The tool will automatically look for a CAN device on the network. Once a unit is detected, it will automatically connect and display the current settings.

NOTE: Only one CAN enabled inverter can be connected to the NVM Setup Utility at a time.

To make a settings change, click on a parameter and the available options will appear in a drop-down menu. Once a setting is changed, the change is immediately set into the inverter's memory. After making all the settings changes, it is necessary to turn the inverter off for 30 seconds and then turn it back on for the setting changes to take effect. The settings may be saved to a configuration file. The configuration file may be used to program any additional units that are to be programmed with the same settings.

Default Configuration

Model	Local Switch	Remote Switch	Low Battery	Shut Down Timer	Load Sense	AUX Control	Battery Type	Branch Circuit Rating	AC Line Qualify	CAN Instance	CAN Baud Rate
LP Standard	Enabled	Momentary	10.5 V	Off	Off	Disabled	N/A	N/A	N/A	1	250 k
LP with "R" Suffix	Disabled	Snap	10.5 V	Off	Off	Disabled	N/A	N/A	N/A	1	250 k
LPC Standard	Enabled	Momentary	10.5 V	Off	Off	Disabled	AGM	15 A	30 Secs	1	250 k
LPC with "R" Suffix	Disabled	Snap	11.0 V	Off	Off	Disabled	AGM	20 A	30 Secs	1	250 k
Setting Options (Set by NVM Setup Utility or Factory)											
Options	Local Switch	Remote Switch	Low Battery	Shut Down Timer	Load Sense	AUX Control	Battery Type	Branch Circuit Rating	AC Line Qualify	CAN Instance	CAN Baud Rate
Options	Enabled	Momentary	10.5 V	Off	On	Disabled	Wet	Disabled	5 Secs	1	250 k
	Disabled	Snap	to	30 Min	Off	RV	AGM	5 A	to	to	500 k
			12.0 V	60 Min		Utility	GEL	to	30 Secs	13	
						Control		20 A			
Increments			0.1 V Steps					5 A Steps	5 Sec Steps		

Switch Options

The inverter can be configured by the factory or through the NVM Setup Utility to have different local and remote switch configurations. The local switch may be set to enabled or disabled. The remote switch may be set to snap or momentary.

If the local switch is set to enabled, the remote switch must be set to momentary. There is one switch combination that is not allowed. If the remote is set to snap, the inverter may not respond correctly to changes in the remote switch's state. Refer to Table 6. This is also true if the inverter remote switch is set to momentary, but a snap style switch is used.

Allowed Switch Options		
Local	Remote Switch Style	
	Snap	Momentary
Enabled	No	Yes
Disabled	Yes	Yes

Table 6 Switch Options

Low Battery Shutdown

Low Battery Shutdown is a protective measure to prevent deep discharge of the battery and/or to make sure that the starting batteries have enough power to start the vehicle.

NOTE: If the inverter is shutdown in low battery conditions, the unit will go into a hard shutdown for under voltage protection (UVP) if the battery is not charged up to the inverter's auto recovery voltage of 13.5 V after 15 minutes. The inverter will be completely off and there will be zero current drawn in UVP. Cycling the "On/Off" switch (remote switch only for "R" suffix) will immediately restart the inverter if the voltage is above the low battery threshold at the DC input terminals.

NOTE: The inverter may be de-rated when the input voltage approaches the low battery set-point. To conserve battery voltage, the internal inverter fan may turn off. This will cause the inverter to go into high temp shutdown if the load is large enough.

Sleep Mode (Load Sense)

The inverter has a sleep mode feature which if enabled can significantly reduce DC power drawn over long periods of no-load operation to help preserve battery life. If sleep mode is enabled, the inverter output will automatically turn off when AC loads greater than 20 W are not present for 60 seconds. The inverter will check for the presence of a load once a second and will automatically restart once a load is detected.

NOTE: While in sleep mode, it may take up to one second for the load to receive power once it has been applied.

NOTE: The LED on the GFCI will blink when the inverter has gone to sleep.

Shutdown Timer

As an alternative to sleep mode, a factory configured shutdown timer is available to disable the inverter after fixed periods (regardless of output load). Standard timer settings are “off,” 30 minutes and 60 minutes. Following the shutdown, the DC input current will be less than 0.5mA. Cycling the on/off control will restart the inverter.

Auxiliary Control

The AUX tab on the side of the inverter allows for additional functionality of the inverter. The AUX tab is set to disabled by default at the factory. To enable the AUX tab, contact the factory or use the NVM Setup Utility. To use the AUX tab, battery voltage needs to be applied to it. The connection should be fused similar to the remote on/off connections shown in Figure 8.

Mode	Description of Mode
Disabled	AUX tab does not do anything
Utility	AUX tab is required to be high (10–16 V applied to tab) to enable the inverter, charger, and bypass.
RV	AUX tab is required to be high (10–16 V applied to tab) to enable the inverter. The charger and bypass are not affected.
Control	AUX tab is required to be high (10–16 V applied to tab) to enable the charger. The inverter and bypass are not affected.

Table 7 AUX Control

NOTE: Applying battery voltage to the AUX tab while the inverter is off will cause the inverter to draw about 170 mA. Remove power from the AUX tab when not using the inverter to conserve battery power.

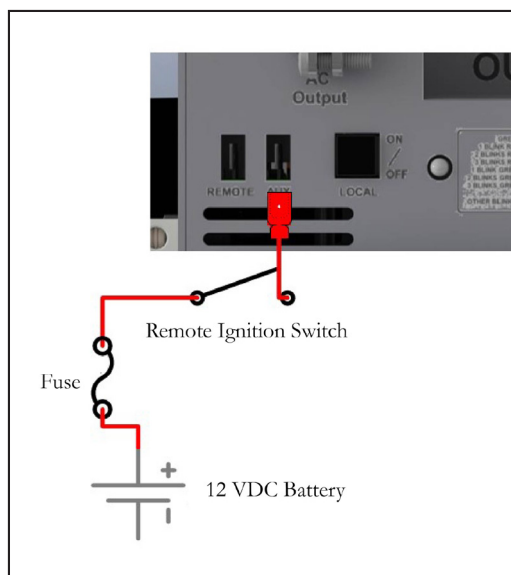

Figure 13 AUX Connection

Battery Options (LPC Only)

The charger can be set to charge three different types of batteries: wet lead-acid, AGM, or gel. The charger is set to AGM by default by the factory. The battery type may be changed at the factory or by the NVM Setup Utility. To determine what type of battery the inverter is configured for, monitor the LED blink code at startup and reference the LED status chart.

Branch Circuit Rating (LPC Only)

The branch circuit rating (BCR) can be set to 0, 5, 10, 15, or 20 A. If set to 0 A, the charger will not enable, but bypass power will still be available. The default factory setting is 15 A. The BCR may be changed at the factory or by the NVM Setup Utility.

AC Line Qualify Time (LPC Only)

The AC line qualification time is the setting that adjusts the time that it takes for the charger and bypass to start once qualified AC power has been applied to the charger input. This time can be set to any value between 5 and 30 seconds, in 5 second increments. The default setting is 15 seconds. This setting may be changed at the factory or with the NVM Setup Utility.

CAN Instance and Baud Rate

The CAN instance can be changed from 1 – 13. This is useful if there are multiple inverters being used on the same CAN network. Multiple inverters should not share the same CAN instance. The baud rate may be changed between 250 k and 500 k. The default settings for the inverter are Instance 1 and Baud rate 250k. These values may be changed at the factory or by the NVM Setup Utility.

NOTE: In the highly unlikely chance that an internal error occurs to the memory of the inverter/charger, the inverter/charger configuration will reset to the 12LPC15 standard. All settings will revert to the standard default configuration, except the battery setting will be set to gel.

TROUBLESHOOTING

⚠ WARNING: Do not remove chassis cover. No user-serviceable parts inside. Call or e-mail customer service for free consultation during business hours. Business hours are 8:00 am –5:00 pm C.S.T.

Phone: 1-800-553-6418 or 1-651-653-7000
 Fax: 1-888-439-3565 or 1-651-653-7600

E-mail: inverterinfo@sensata.com
 Website: <http://magnum-dimensions.com/>

LED Status Chart – Normal Operation

Status LED Normal States

LED Color & State	Remote LED State	Operating Condition
Green — 1 blink	Constant on	Bulk Charge
Green — 2 blinks	Constant on	Accept Charge
Green — 3 blinks	Constant on	Float Charge
Green — 4 blinks	Constant on	Load Management Active
Green — 5 blinks	Constant on	Equalization Mode
Green — 6 blinks	Constant on	Monitor Mode
Green — Solid	Constant on	Inverting

Battery Type Local LED States at Start-Up (5 Minutes)

Amber — Green	Wet Lead-Acid
Amber — Green — Green	AGM
Amber — Green — Green — Green	Gel

Table 8 LED Status

NOTE: The LED will blink an amber-green pattern indicating the battery type during the first 5 minutes of operation upon initial power-up. The pattern will cease if a warning or fault occurs.

Inverter Faults and Warnings

Inverter Status LED Fault States

LED Color & State	Remote LED State	Operating Condition
None	Off	No Power to Unit or Internal Fault
Amber — Solid	Constant on	Low Battery 0–5 Seconds (Warning)
Red — Solid	Constant on	Overload 0–5 Seconds (Warning)
Red — 1 blink	1 blink	Inverter Low Battery Shut Down**
Red — 2 blinks	2 blinks	Inverter Overload Shut Down
Red — 3 blinks	3 blinks	High Temp Heatsink*
Red — 4 blinks	4 blinks	System Overload, Output Short Circuit**
Red — 5 blinks	5 blinks	High Battery 0–5 Minutes
Red — 6 blinks	6 blinks	High Battery >5 Minutes
Red — 7 blinks	7 blinks	High Temp Transformer
Red — 8 blinks	8 blinks	Inverter Off by CAN

Table 9 Inverter Faults and Warnings

* Faults will self-recover when the condition returns to normal range

** Faults may be due to a short-circuited output or a low or weak DC voltage source.

- **Low Battery 0–5 Seconds:** The DC voltage measured at the inverter input terminals has dropped below the low battery setpoint.
- **Overload 0–5 Seconds:** Overload condition has been detected. If the condition clears within 5 seconds, the LED will return to normal state.
- **Inverter Low Battery Shutdown:** After five seconds of low battery, the inverter will shut down if the DC voltage has not recovered. The inverter will automatically restart if the battery voltage rises above a preset threshold within 15 minutes. If the battery voltage does not recover within 15 minutes, the inverter will completely shut down and the inverter will need to be restarted with a local or remote switch.
- **Inverter Overload Shutdown:** The inverter power will need to be cycled to restart the inverter. If the overload condition exceeds 108% of the rated load for greater than 1.5 seconds, the inverter will shut down. The inverter power will need to be cycled to restart the inverter. If the overload condition exceeds 200% of rated load, the inverter will shut down immediately.

NOTE: The inverter will only permit an overload event to exceed 108% of rated load once every 30 seconds. For example, the inverter may go into overload when starting up a compressor. 30 seconds must pass before attempting to start the compressor again.

- **High Temp Heatsink:** The internal inverter heatsink temperature has exceeded the preset limit, and the inverter will shut down in high temp.
- **System Overload/Output Short Circuit:** The inverter has detected that the output has short circuited. If the input voltage to the inverter is approaching the low battery setpoint and a heavy load is applied, the output voltage may collapse, causing the inverter to fault like an output short circuit. The inverter power will need to be cycled to restart the inverter.
- **High Battery 0–5 Minutes:** DC voltage measured at the inverter input has exceeded the maximum rating of the inverter for up to five minutes, and there will be a high battery fault. If the battery voltage drops below the high voltage threshold, the LED will return to its normal state.

Inverter Faults and Warnings Continued

- **High Battery >5 Minutes:** DC voltage has not dropped below the high voltage threshold in under 5 minutes, and the inverter will shut down. The inverter will resume normal operation when the voltage drops below the high battery threshold.
- **High Temp Transformer:** The transformer temperature has exceeded its limit, and the inverter will shut-down. The inverter will automatically restart once the inverter has cooled down.
- **Inverter Off by CAN:** The inverter has been turned off with a CAN command.

Charger Faults and Warnings

Charger Status LED Fault States

LED Color & State	Remote LED State	Operating Condition
None	Off	No Power to Unit or Internal Fault
Amber — 1 blink	Fast blink	Charger Off — Check Battery Probe
Amber — 2 blinks	Fast blink	Charger — Warm Battery*
Amber — 3 blinks	Fast blink	Charger Off — High Battery Voltage*
Amber — 4 blinks	Fast blink	Charger Off — High Battery Temp
Amber — 5 blinks	Fast blink	Charger Off — Low Battery Voltage
Amber — 6 blinks	Fast blink	Charger Off — High Temp Transformer*
Amber — 7 blinks	Fast blink	Charger Off — High Temp Heatsink*
Amber — 8 blinks	Fast blink	Charger Off — 0 Amp Limit Set
Amber — 9 blinks	Fast blink	Charger Off — Overcurrent Shutdown
Amber — 10 blinks	Fast blink	Charger Off — Disabled by CAN

Table 10 Charger Faults and Warnings

* Faults will self-recover when the condition returns to normal range

- **Warm Battery:** The battery temperature has measured between 50°C and 59.9°C. The charger will reduce the charge current to its minimum level.
- **High Battery Voltage:** There may be an issue with the vehicle's alternator. Disconnect the inverter/charger from the battery before examining the vehicle's electrical system.
- **High Battery Temp:** The battery temperature exceeds 60.0°C, and the charger will shut down. The charger will need to be restarted once the battery has cooled down.
- **Low Battery Voltage:** The battery voltage measured at the charger DC terminals has dropped below a threshold, and the charger will shut down. The charger will need to be restarted once the battery voltage has recovered.
- **High Temp Transformer:** The transformer temperature has exceeded its limit, and the charger will shut down. The inverter will automatically restart once the inverter has cooled down.
- **High Temp Heatsink:** The internal heatsink temperature has exceeded the preset limit, and the charger will shut down in high temp.
- **Zero Amp Limit Set:** The charger will turn off if the branch circuit rating (BCR) setting has been set to zero. Setting this feature to zero limits the power that can be used for the charger to zero. Bypass power is still available.
- **Overcurrent Shutdown:** The output has short circuited, and the charger will immediately shut down.
- **Disabled by CAN:** The charger has been turned off with a CAN command.

Troubleshooting Guide

Problem	Possible Causes		
No AC output during inverter mode	Check if the in-line fuse which is located within 18" from the battery's positive post is installed or open.		
	Check if DC connections are tight and clean.		
	Check if the AC output circuit breaker is tripped.		
	Check if the switches are on. Check if any of the wires connected to the remote switches are loose or disconnected. (Local switches are inactive with "R" configurations.)		
	Check if the GFCI is tripped. Reset the unit if necessary by cycling power.	If GFCI is set, disconnect all loads and connect a test light. If the test light is off, replace the GFCI or return the inverter for service.	
	For hardwired connections, remove DC input voltage and inspect the AC hardwire connections.		
Low Battery	The use of a battery isolator is not recommended due to excessive voltage drop across isolator terminals.		
	Battery voltage must be above the low battery threshold (measured at the inverter) for the inverter to be on.		
	Check for proper DC wire AWG (see DC Wire Gauge & Fusing section.)		
Overload	Unplug all loads and reset the inverter. To reset, turn the unit off and wait for 30 seconds to turn on again.	If the overload condition clears, check for short circuits or check the load size versus the inverter output wattage size.	
		If the overload persists, possible failed inverter.	
High Temperature	Let the unit cool down.		
	Verify that all vent openings are clear of obstruction.		
	Reduce ambient temperature and/or load.		
Inverter will not turn off	Verify that all remote "On/Off" switches are in the "Off" position.		
Charger or bypass will not enable	Verify that the AC input voltage is between 90 V and 130 Vrms.		
	Verify that the AC input breaker has not tripped.		

Table 11 Troubleshooting

NOTE: If the status LEDs are illuminated, refer to the "LED Status Chart" for additional information.

NOTE: Whenever cycling power, wait at least 30 seconds before turning back on to allow the inverter processor to completely power down. If the processor does not power down, it may retain the previous fault state.

APPENDIX

Accessories & Replacement Parts

Part Number	Item Description
430005	GFCI outlet, Leviton GFNT2
431021	Fuse holder with cover
430012	Fuse 350 A, ANN-350
430010	Fuse 200 A, ANN-200
430011	Fuse 250 A, ANN-250
430012	Fuse 300 A, ANN-300
612007	20 ft. LED remote momentary switch cable (other length available)
510031	Non-illuminated momentary switch (no cable)
612016	20 ft. LED remote snap switch cable (other lengths available)
ME-BTS-XX	Temperature sensor (-xx = 6, 8, 15, 25, or 40 for length in ft.)
245052	NVM Setup Utility kit (includes cable, terminating resistor gender changer, CAN interface, and software)
612015-CAN	NVM Setup Utility (provided on a flash drive)

Table 12 Accessories

GFCI MFG	Catalog No.
Leviton	GFNT2-
Hubbell	GFR5362SGW
Cooper Wiring	TRSGF20
Pass & Seymour (Legrand)	2097

Table 13 GFCI Replacement Options

Inverter Model Options

Other options are available. Contact the factory for more information.

Options	Description
A	AC terminals protected by GFCI
H	Hardwire only, no GFCI
R	Remote only, local switch inactive

Table 14 Model Options

NOTE: Options “A” and “H” may not be used in the same inverter

NOTE: For hardwired models installed in recreational vehicles without GFCI, the installer must install a GFCI in order to comply with NFPA 70.

CAN

The inverter is compatible with RV-C CAN, developed by the RVIA (Recreational Vehicle Industry Association). CAN allows for the inverter to communicate with other units on the network.

For CAN to work properly, the inverter and all other units on the CAN network must be using the same CAN protocol. If the protocols are different, the units will not recognize each other.

The typical RV-C CAN network is operated at 250 kbit/s, although the inverter may be configured for 500 kbits/s. Up to 13 inverter/chargers can be placed on the CAN network. Each inverter/charger requires a unique instance to differentiate itself from similar units. If the inverter is connected to a network operating at a different Baud rate or a network that uses a proprietary communications protocol, the inverter may not respond.

The inverter/charger supports most standard RV-C instructions in addition to several custom commands for configuration changes. Contact the factory for more information.

Supported Standard RV-C instructions include (not limited to):

Command	Command Description
Charger Command	Enable or disable the charger
Charger Config Cmd 2	Set the branch circuit rating
General Reset	Reboot the inverter/charger
Inverter Command	Enable or disable the inverter

Table 15 CAN Commands

Status	Status Description
Charger Config Status 1	Returns yes or no if the battery temp sensor is present, the battery type, and max charge amps for the charger
Charger Config Status 2	Returns the branch circuit rating setting and the default battery temperature
Charger Equalization Status	Returns the minutes remaining in the equalization process and the pre-charge status
Charger Status	Returns charge voltage, charge current, the current charge mode
Charger AC Status 1	Returns the input Vrms, Arms, and line frequency
Charger AC Status 2	Returns the branch circuit rating
DC Source Status 1	Returns the charger output VDC and ADC
DC Source Status 2	Returns the battery temperature °C
Inv AC Status 1	Returns the inverter output Vrms, Arms, and frequency
Inv AC Status 3	Returns the inverter output watts
Inverter DC Status	Returns the inverter input VDC
Inverter Status	Returns the inverter/charger instance ID, RVC status, and the inverter/charger status bits
Product ID	Returns the model number and serial number

Table 16 CAN Status

Setting Notes (Set by NVM Setup Utility or Factory)

Model	LP Standard <input type="checkbox"/>	LP "R" Suffix <input type="checkbox"/>	LPC Standard <input type="checkbox"/>	LPC "R" Suffix <input type="checkbox"/>
Local Switch	Enabled <input type="checkbox"/>		Disabled <input type="checkbox"/>	
Remote Switch	Momentary <input type="checkbox"/>		Snap <input type="checkbox"/>	
Low Battery	Min	Max	<input type="text"/>	
	10.5 V	12 V		
	.1 V Increments			
Shut Down Timer	Off <input type="checkbox"/>	30 Minutes <input type="checkbox"/>	60 Minutes <input type="checkbox"/>	
Load Sense	On <input type="checkbox"/>		Off <input type="checkbox"/>	
AUX Control	Disabled <input type="checkbox"/>	RV <input type="checkbox"/>	Utility <input type="checkbox"/>	Control <input type="checkbox"/>
Battery Type	Wet <input type="checkbox"/>	AGM <input type="checkbox"/>	GEL <input type="checkbox"/>	
Branch Circuit Rating	Disabled	Min	Max	<input type="text"/>
		5 A	20 A	
		5A Increments		
AC Line Qualify	Min	Max	<input type="text"/>	
	5 Seconds	30 Seconds		
	5 Sec Increments			
CAN Instance	Min	Max	<input type="text"/>	
	1	13		
CAN Baud Rate	250K <input type="checkbox"/>		500K <input type="checkbox"/>	
Serial Number	<input type="text"/>			

LIMITED WARRANTY TERMS & CONDITIONS

SHIPPING TERMS: F.O.B. St. Paul Minnesota. Freight prepaid and billed, subject to prior credit approval.

MINIMUM ORDER: \$50.00 Net Price

LOSS OR DAMAGE: Loss or damage in transit are the responsibility of the carrier. Any claim should be filed with the delivering transport company. Invoice, Bill of Lading and Delivery receipt with damage noted therein must accompany any claims for freight damage. Claims for shortage and lost shipments must be made in writing to Sensata Technologies within 10 days of date of shipment. Claims not reported within this time frame will not be honored.

PRICES: Prices are subject to change without notice. All orders are subject to acceptance at the factory. We reserve the right to invoice prices in effect at time of shipment.

TERMS: Net 30 days with approved credit, credit card or C.O.D.

RETURN GOODS POLICY:

- No returned materials will be accepted without an accompanying Returned Materials Authorization Number (RMA) from the factory.
- Credit will be issued for returned goods to the original purchaser within 60 days of purchase, provided the inverter is returned to Sensata unused and not mounted. The amount of credit will be issued at Sensata's discretion based on the condition of the product.
- Customer must be in good standing with Sensata Technologies.
- Inverters that are discontinued, high-voltage (over 24 VDC), special-order or reconditioned are excluded and will not be eligible for credit. Non-inverter items such as cable assemblies, fuses and fuse holders, will not be eligible for credit
- Support components supplied by Sensata vendors will be covered under that manufacturer's credit return policy.
- Customer pays return freight.

PLEASE SHIP AUTHORIZED RETURNS TO:

Sensata Technologies RMA# _____, 4467 White Bear Parkway, St. Paul, MN 55110. Return Freight Prepaid.

LIMITED WARRANTY:

Sensata Technologies extends the following warranty to the original purchaser of those goods subject to the qualifications indicated. Sensata warrants to the original purchaser for use that the goods or any component thereof manufactured by Sensata will be free from defects in workmanship from the date of purchase for the period listed on the product label, provided such goods are installed, maintained and used in accordance with Sensata and the original manufacturer's written instructions. Damages caused by the misuse, undue care or obvious wear through use will not be covered by this warranty.

Components not manufactured by Sensata, but used within the assembly provided by Sensata, are subject to the warranty period as specified by the individual manufacturer of said component, provided such goods are installed, maintained and used in accordance with Sensata and the manufacturer's written instructions.

Sensata's sole liability and the Purchaser's sole remedy for a failure of goods under this limited warranty and for any and all claims arising out of the purchase and use of the goods shall be limited to the repair or replacement of the goods that do not conform to this warranty.

SENSATA RETURN PROCEDURE:

To obtain repair or replacement service under the limited warranty, the purchaser must contact the factory for a Return Material Authorization (RMA) Number. Once obtained, send the RMA Number along with the defective part or goods to:

Sensata Technologies RMA# _____, 4467 White Bear Parkway, St. Paul, MN 55110. Return Freight Prepaid.

THERE ARE NO EXPRESS WARRANTIES COVERING THESE GOODS OTHER THAN AS SET FORTH ABOVE. THE IMPLIED WARRANTIES OF MERCHANTABILITY AND FITNESS FOR A PARTICULAR PURPOSE ARE LIMITED IN DURATION TO ONE YEAR FROM DATE OF PURCHASE.

SENSATA TECHNOLOGIES ASSUMES NO LIABILITY IN CONNECTION WITH THE INSTALLATION OR USE OF THE PRODUCT, EXCEPT AS STATED IN THIS LIMITED WARRANTY. SENSATA TECHNOLOGIES WILL IN NO EVENT BE LIABLE FOR INCIDENTAL OR CONSEQUENTIAL DAMAGES.

WARNING: LIMITATIONS ON USE: DIMENSIONS™ brand products are not intended for use in connection with Life Support Systems and for Avionic use. Sensata Technologies® makes no warranty or representation in connection with their products for such uses.

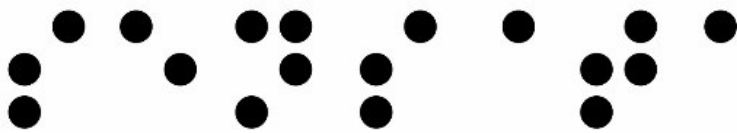

Sensata

Technologies

The World Depends on Sensors and Controls

4467 White Bear Parkway
St. Paul, MN 55110

Phone: 651-653-7000, 800-553-6418

Fax: 651-653-7600, 888-439-3565

inverterinfo@sensata.com
<http://magnum-dimensions.com/>

Document# 122221 Revision B
12LPC15 Manual