

Manufacturer of Dimensions™ Inverters
4467 White Bear Parkway
St. Paul, MN 55110
Phone: 651-653-7000 Fax: 651-653-7600
E-mail: inverterinfo@sensata.com
Web: www.dimensions.sensata.com

Form: 122028C
December 2012

ISO 9001 Registered Company

DIMENSIONS™

DC to AC Power Inverters

Owners Manual for Models:
MIL-24X26UVQ

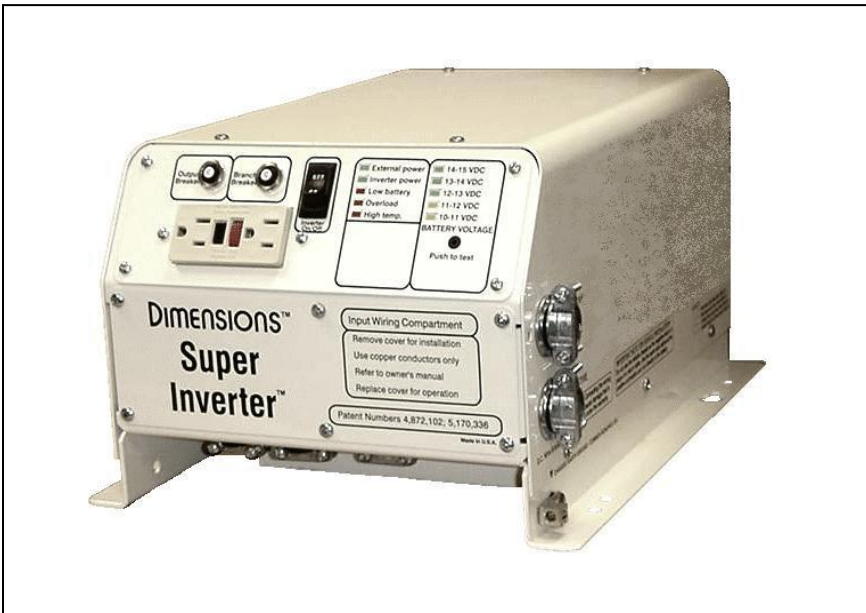

TABLE OF CONTENTS

| Section | Description | Page |
|---------|--------------------------------------------------|------|
| 1 | General | 3 |
| 1.1 | Safety Instructions | 3 |
| 1.2 | Introduction | 5 |
| 1.3 | Specifications | 6 |
| 2 | Description | 7 |
| 2.1 | Controls and Indicators | 7 |
| 2.2 | Control Panel LED Indicators | 8 |
| 2.5 | Support Items | 9 |
| 3 | Installation | 12 |
| 3.1 | Inverter Components and Installation Tools | 12 |
| 3.2 | Mounting the Inverter..... | 13 |
| 3.3 | Inverter Wiring | 14 |
| 4 | Operation | 18 |
| 4.1 | Startup | 18 |
| 5 | Troubleshooting | 19 |
| 5.1 | Inverter Troubleshooting | 19 |
| 5.2 | Troubleshooting LED Messages | 20 |
| 6 | Appendix | 21 |
| 7 | Glossary | 25 |
| 8 | Limited Warranty | 27 |

1.1 Safety Instructions

Save This Manual

Read this manual before installation, it contains important safety, installation, and operating instructions. Keep it in a safe place.

All wiring must follow the National Electric Code, Provincial or other codes in effect at the time of installation, regardless of suggestions in this manual. All wires should be copper conductors.

1.1.1 Warning and Danger Symbols

To reduce the risk of electrical shock and to ensure the safe operation of your Dimensions power inverter, the following symbols are used throughout the manual.



ATTENTION: Important operating instructions. Follow them closely.



DANGER: Risk of personal harm and/or electrocution exists in this area. Use extreme caution.

1.1.2 Inverter Precautions

- Inverters produce hazardous voltages. To avoid risk of harm or fire, the unit must be properly installed.
- There are no user serviceable parts inside, do not remove the cover.
- The inverter should not be mounted in a location that may be exposed to rain or water spray.
- The inverter should not be installed in a zero clearance enclosure.
- Damage to the inverter will occur if correct polarity is not observed when installing the DC input cables.
- Damage to the inverter will occur if an external AC power source is applied to the inverter's AC hardwire output.
- The inverter contains a circuit breaker and capacitor that may produce a spark. Do not mount in a confined battery or gas compartment.
- Be sure the inverter is turned OFF during installation.

1.1.3 Battery Precautions

- Working in the vicinity of lead-acid batteries is dangerous. There is a risk of acid exposure.
- Batteries generate explosive gases during operation.
- There is risk of high current discharge from shorting a battery that can cause fire and explosion. Use insulated tools during installation.
- Remove all rings, watches, jewelry or other conductive items before working near the batteries.
- Inspect the batteries once a year for cracks, leaks or swelling.
- Dispose of the batteries according to local regulations. Do not incinerate batteries; risk of explosion exists.

1.2 Introduction

When operating, the direct current (DC) that enters the inverter from the batteries is filtered by a large input capacitor and switched "On" and "Off" by the Metal Oxide Silicon Field Effect Transistors (MOSFET) at a rate of 60 cycles per second, and directed into the transformer which steps the voltage up to 120 volts. The unit has a Digital System Processor (DSP) to control the output voltage and frequency as the DC input voltage and/or output load varies. The 120 VAC, 60 Hz alternating current (AC) signal waveform output is quasi-sine, which is different from a pure sine waveform (see appendix section H, page 24 for waveform discussion).

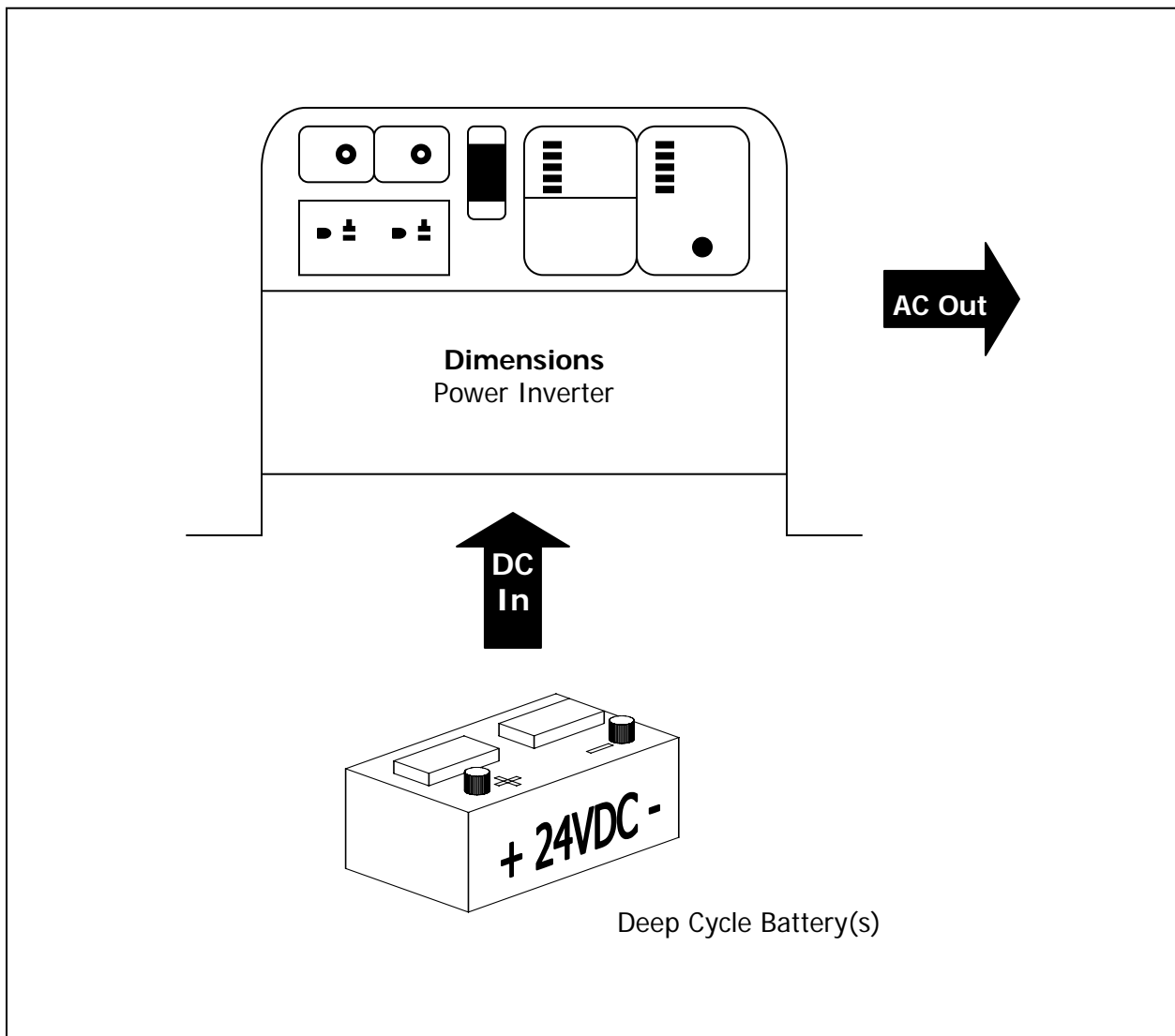

FIGURE 1: Power inverter block diagram

1.3 Specifications

| | |
|----------------------------------|---------------------------------------------------|
| Inverter Model | 24X26UVQ |
| Output Power (Continuous @ 50°C) | 2600 Watts |
| Peak Current AC | 90 amps |
| Output Current AC | Up to 30 amps |
| Output Rating | 1 ½ HP |
| Input Current DC | Up to 130 amps |
| Weight | 55 Lb |
| Chassis Size: LxHxW | 15.75"x11.5"x7.75" |
| Output Voltage: | 120 VAC RMS ± 5% |
| Output Frequency: | 60 Hz +/- 0.05% |
| Output Waveform: | Quasi-sine with waveform stabilizer, single-phase |
| Input Voltage: | 22 to 28 Volt DC |
| Efficiency: | Up to 92% |
| Operating Temperature: | -20°C to 40°C (0°F to 104°F) |

Design Features:

- Thermally controlled cooling fan.
- Heavy duty conformal coating of the printed circuit board ("Q").
- Vent-less cover ("V") to protect the inside electronics from the elements.
- Powder-coated case
- Large case TO247 MOSFET design.
- High peak power for motor starting ability.
- Enclosed AC and DC cable connections with strain relief.
- Remote on/off switch hookup.
- GFCI outlet protection.
- LED indications:
 - Inverter power
 - Low battery
 - Overload
 - High temperature
 - Battery voltage.

Battery Protection:

- Low battery shutdown at 21VDC with in-rush delay.

Unit Protection:

- Automatic electronic short circuit protection
- Automatic electronic overload protection
- Automatic high temperature shutdown
- Output circuit breaker

Usage:

- This inverter may be used to power 120 VAC, 60 Hz single-phase equipment within the inverter power rating, unless specifically requiring a pure sine waveform.

2.1 Controls and Indicators

2.1.1 Inverter Module Description

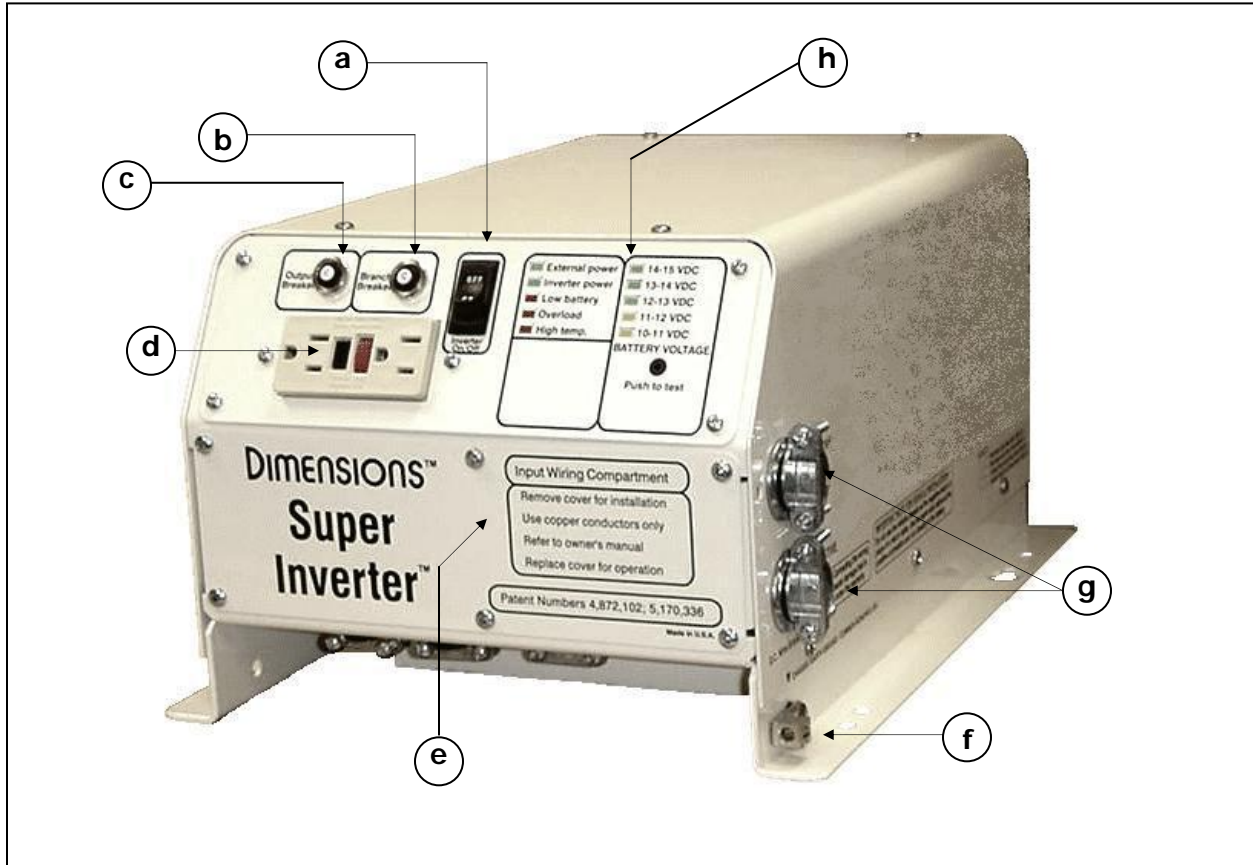

FIGURE 2: Chassis physical description

- (a) **Inverter On/Off switch:** Switches the inverter on or off
- (b) **Output Breaker:** Trips to protect the inverter from hardwire AC output short circuit or overload.
- (c) **Branch Breaker:** Trips to protect the inverter from GFCI outlet short circuit or overload.
- (d) **GFCI outlets:** Two outlets, output power 120 VAC 60 Hz.
- (e) **Field Wiring Compartment:** DC input and AC output power connections are made here. Remove the faceplate to access the field-wiring compartment.
- (f) **Chassis Bonding Lug:** Connects to vehicle chassis.
- (g) **DC Input:** Connects the DC cables from the batteries.
- (h) **Control panel:** See description on page 8

2.1.2 LED Control Panel Description

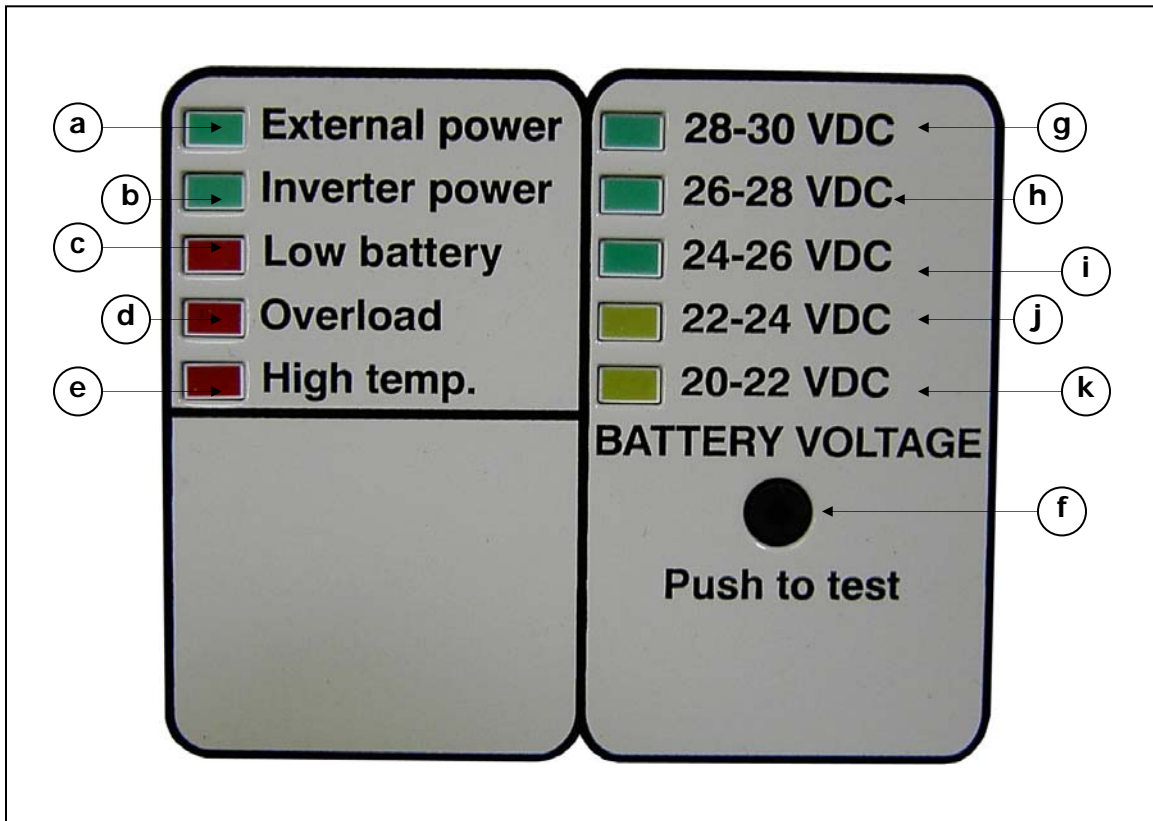

FIGURE 3: LED Front Control Panel

- (a) **External power:** Not used.
- (b) **Inverter power:** The green LED indicates that the inverter is operating.
- (c) **Low Battery:** The red LED indicates a low battery voltage condition.
- (d) **Overload:** The red LED indicates an overload condition.
- (e) **High temp:** The red LED indicates a high internal temperature.
- (f) **Push to test:** Pressing this button enables the battery voltage LEDs.
- (g) **28 – 30 VDC (Battery voltage):** Green LED.
- (h) **26 – 28 VDC (Battery voltage):** Green LED.
- (i) **24 – 26 VDC (Battery voltage):** Green LED.
- (j) **22 – 24 VDC (Battery voltage):** Yellow LED.
- (k) **20 – 22 VDC (Battery voltage):** Yellow LED.

2.2 Support Items

2.2.1 General Overview

An inverter support system consists of all the equipment needed to supply DC power to the inverter. On a land vehicle the support system can be divided into two main categories depending on the size of the loads and their running time, these are: Light duty applications and heavy-duty applications.

The typical support system in a light duty application of less than 2000 Watts of constant power drawn for up to one hour, consists of an OEM engine battery with one or two auxiliary deep-cycle batteries, the existing OEM engine alternator, and the necessary cables and fuses. The batteries alone are able to power the loads without running the vehicle engine.

In heavy-duty applications, the batteries alone cannot supply long-term power for large loads. Ultimately, the energy must come from the engine alternator, and the vehicle's engine will need to be running. In some cases the existing alternator is replaced by a heavy duty high-output alternator, along with a high idler control device designed to provide high 24 Volt current during high idle. Even with these special alternators and the high idler control device, a large battery bank is typically needed to supply the balance of 24 Volt current to the inverter. In some cases two alternators running in parallel are necessary.

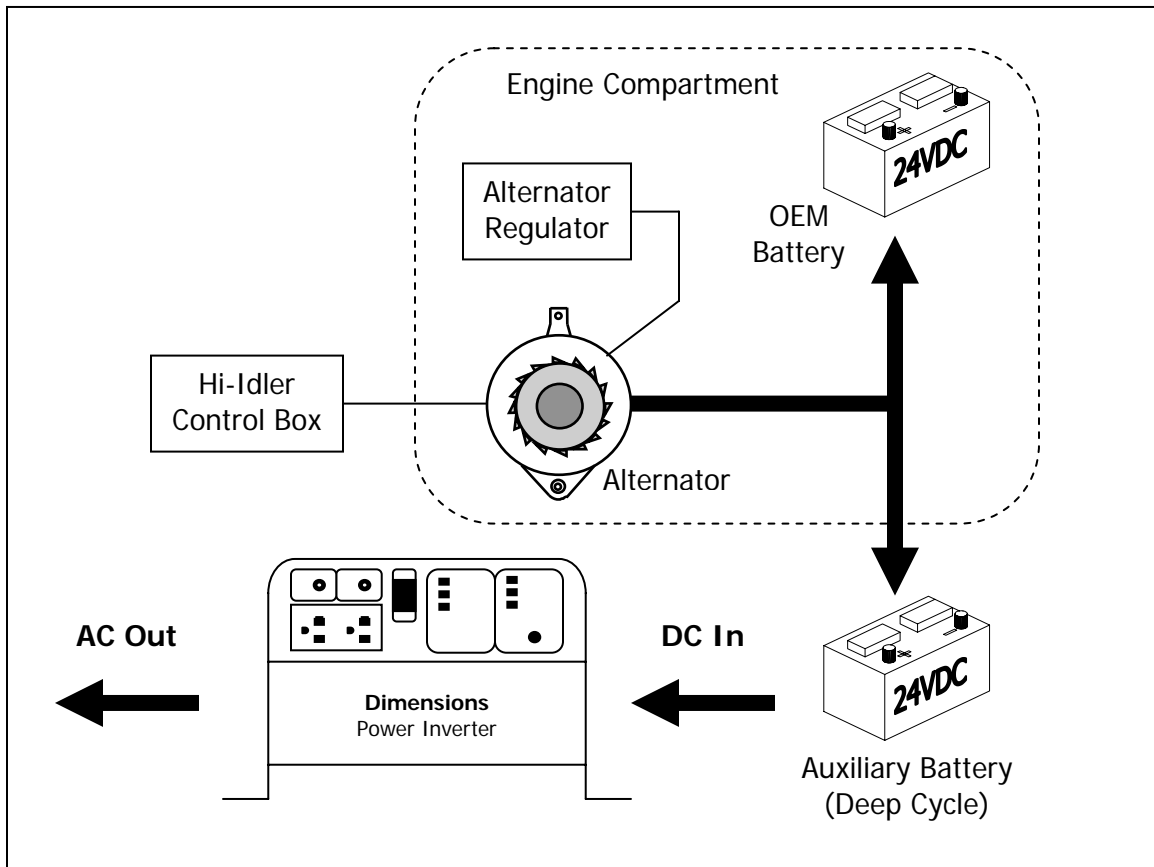

FIGURE 4: Inverter Support Items Block Diagram

2.2.2 Deep Cycle Battery Theory

There are two categories of lead acid deep cycle batteries; wet and sealed. Sealed batteries can be either gel cell or AGM (Absorbent Glass Mat) type. Deep cycle batteries are designed specifically for repetitive charge and discharge cycles. These batteries are also made to be discharged to a very low level before recharging. Their plates are thicker than automotive starting batteries.

Deep cycle battery power capacity is rated in amp hours with a given discharge time typically at 20 hours. A 100-amp hour battery will produce five amps for twenty hours before it is exhausted. Automotive starting batteries are rated in cold cranking amps and are not recommended for inverter applications.



We strongly recommend using auxiliary deep cycle batteries with your Dimensions inverter. Do not use only the engine starting battery.

a) Wet Cell Batteries: Characterized by their relatively thick internal plates that are alloyed with antimony. These batteries will gas when charging resulting in some water loss. It is very important that the electrolyte level be checked frequently and filled with distilled water when necessary.

b) Sealed Batteries: Can be either gel cell or AGM type and do not require periodic electrolyte replenishment.



*Sealed batteries will **NOT** tolerate overcharging*

- **Gel Cell Batteries:** The chemical composition and construction of these batteries are unique. The electrolyte is mixed with a silica material, which converts it into a gelatin. This keeps the water and acid mixed and allows the battery to be used in any position, as there is no liquid to run out. These are the safest for use indoors. They are the least affected by temperature extremes (especially freezing.) Their tolerance for being stored at low state of charge levels is excellent. Gel cell batteries do not require maintenance, have low self-discharge rate and low internal resistance.

- **AGM Batteries:** These are lead acid, maintenance-free batteries and their performance is similar to gel cell batteries. The liquid electrolyte has been absorbed into fiberglass cloth mats between the plates. They have good deep cycle characteristics and can be used in most positions. They are less affected by temperature extremes than a wet cell type battery but are more sensitive than a gel cell battery. AGM batteries do not tolerate storage at a low state of charge as well as a gel cell but will handle overcharging slightly better. The charging characteristics are similar to gel cell batteries.

2.2.3 Battery Cable Assembly

Use stranded copper cable for the battery-to-inverter cable and for the battery-to-alternator cable as indicated. An in-line fuse must be installed between the battery and the inverter and between the battery and alternator. U.L. requires that the fuse be within 18 inches of the battery.



Use SGX cross-linked polyurethane that complies with SAE J-1127 and vehicle manufacturer requirements as well as high temperature insulation requirements (135°C.) of SAE J-1127.

a) Battery-to-Inverter Cable: If furnishing your own battery-to-inverter cable see figure 5 below, also see cable and fusing guide charts A and B in appendix section 6, page 21 then follow these steps:

- Locate your inverter model in chart A.
- Estimate cable length (distance between the inverter and the battery) then choose the appropriate length on chart A.
- Using chart A, find the correct gauge of cable needed
- Cross-reference the wire gauge found above to select the proper fuse size in chart B.

⚠ *Using smaller battery-to-inverter cable or longer length will greatly degrade inverter peak performance.*

b) Battery-to-alternator cable: Determine your vehicle's alternator output current. If furnishing your own cable, see figure 5 below and also refer to chart C in Appendix section 6, page 21 to determine wire gauge and fuse sizes.

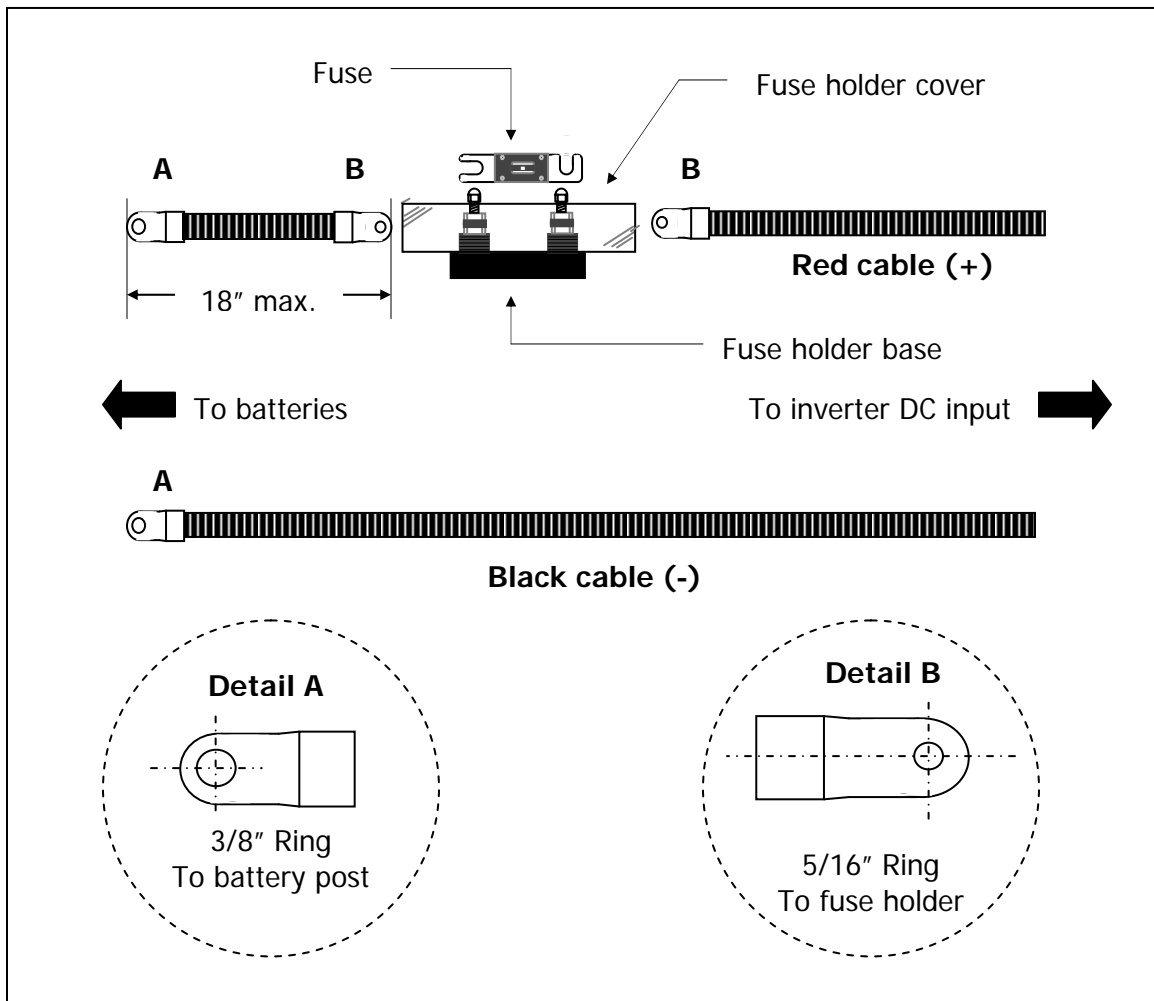



FIGURE 5: Inverter Cable Assembly

3.1 Inverter Components and Installation Tools

3.1.1 List of Inverter Components

Check your packing slip against the following chart; make sure you received all the components listed.

| Picture | Description and Part Number | Quantity |
|-----------------------------------------------------------------------------------|-----------------------------|----------|
|  | Inverter module 24X26UVQ | 1 |

3.1.2 Tools for Installation

Below is the list of useful tools required for the installation of the inverter

- Connectors (butt type and insulated)
- Cordless drill with bits and spare battery pack
- Crimpers (for insulated and non-insulated connectors)
- Digital Volt Meter with probes
- Electrical Tape
- #2 Phillips Screwdriver
- 3/8" Allen wrench, Socket Wrench
- Wire cutters, Wire strippers, Cable ties, Tape measure
- 1/4" diameter screws.

3.2 Mounting the Inverter

3.2.1 Mounting the Inverter Module:

⚠ *The inverter mounting location should provide adequate ventilation and clearance to maintain room temperature during operation. At least 1/2 inch of clearance is required on all sides.*

- Locate a suitable, secure vertical or horizontal mounting surface as close to the batteries as possible without being in the same airtight compartment.
- If mounting the inverter on a vertical surface, it is recommended that the front control panel be pointing down whenever possible.
- Locate the keyholes at the rear of the chassis flanges and fasten them using 1/4 inch diameter screws. See figure 6, inverter footprints on this page below.
- Let the inverter slide down over the keyholes. Tighten the screws.
- Fasten the screws through the front holes to secure the inverter.

3.2.2 Mounting the Battery Bank:

⚠ *Do not use vehicle-starting batteries; deep discharge cycles typical with inverter applications can shorten the life of this type of battery.*

- It is recommended to mount the battery bank close to the inverter. The maximum recommended distance between the inverter and the battery bank is 20 feet.
- The battery compartment must be vapor-tight to the interior of the vehicle and vented directly to the exterior.
- Install several vent-plugs within one inch of the top of the battery compartment to allow for ventilation. Install a ventilation assembly as needed.
- Allow space around the battery and especially above the battery for inspection, and maintenance purposes.
- The battery should not be able to move more than 1 inch in any direction.

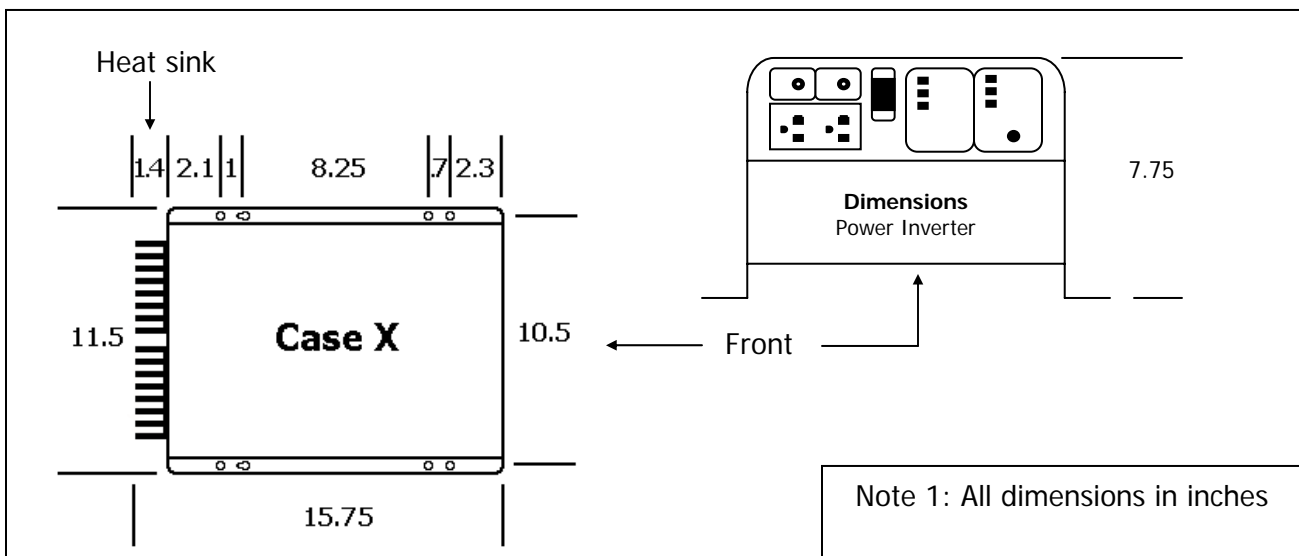

FIGURE 6: Inverter footprint

3.3 Inverter Wiring

Reference figure 7, page 16 DC wiring and figure 8, page 17 AC wiring diagram.

3.3.1 Grounding: Connect an 8 gauge copper wire between the bonding lug located at the right side of the chassis on the inverter and the earth grounding system of the vehicle chassis. See figure 2, item (f) page 7.

3.3.2 Battery-to-Inverter Cable Assembly



An initial spark may result when connecting the final battery wire to the inverter due to charging of the internal input capacitors.



Connecting the inverter with the DC polarity reversed to the battery will cause damage that is not covered under the warranty.

- a) Refer to Figure 7: DC wiring diagram.
- b) Open the inverter field-wiring compartment to access the DC input lugs.
- c) Unscrew the DC input lug POS (+) and NEG (-) 3/8" Allen screws.
- d) Remove the fuse from the fuseholder for cable installation.
- e) Remove 1 inch of insulation from the un-terminated ends of the red and black cables.
- f) Insert the stripped end of the red wire into the DC input lug labeled POS (+) and the stripped end of the black wire into the DC input lug labeled NEG (-). Tighten the 3/8" Allen screws to 23 Ft. Lbs.
- g) Tighten the cover DC cable strain relief screws to 1 Ft. Lb.
- h) Connect the end of the short red cable to a POS (+) battery post.
- i) Connect the terminated end of the black cable (neg. return cable) directly to a battery NEG (-) post (DO NOT connect to the chassis).
- j) Install the in-line fuse in the fuseholder that is within 18" of the positive post of the battery bank (a one-time spark will occur when this final DC connection is made). To determine the fuse size, refer to the Appendix.

3.3.3 Auxiliary Battery-to-Alternator or OEM Battery Cable Assembly



Do not use the vehicle chassis as a return path. Use the same wire gauge as the positive cable to complete the connection.

- a) Turn vehicle engine off.
- b) Disconnect the cable from the vehicle battery negative post.
- c) Remove the in-line fuse from the fuse holder located on the red or positive (+) assembly wire.
- d) Bolt the cable ends with ring terminals positive (+) and negative (-) to the vehicle alternator output.
- e) Using washers and nuts, place the assembly wire ring terminals to the appropriate positive (+) and negative (-) auxiliary battery post.
- f) Reinstall the in-line fuse into the fuse holder.
- g) Reconnect the cable to the vehicle battery negative post.
- h) To determine the fuse size, refer to the Appendix.

3.3.4 Remote On/Off Switch: An optional customer supplied remote On/Off switch may be connected to the inverter and mounted at a convenient location. The remote switch will operate only if the inverter On/Off switch on the face of the inverter is turned on.

- a) Remove the in-line fuse from the fuse holder located on the positive (+) battery to inverter assembly wire.
- b) Remove the front field wiring cover plate to access the wiring compartment. See figure 2, item (e), page 7.
- c) Remove the violet wire from the battery positive input terminal in the wiring compartment marked "Remote Switch Hookup".
- d) Connect the violet wire to the load side of the On/Off remote switch.
- e) Connect a fused (5 amp recommended) +24VDC battery voltage to the line side of the switch. Use 18-gauge wire. The fuse should be mounted within 18 inches of the battery.
- f) Make sure the inverter switch is OFF before putting the in-line fuse back into the fuse holder removed on step (a). A spark may result due to a capacitor charging.
- g) Replace the front field wiring cover plate.

3.3.6 120 VAC 60Hz Output



Make sure the inverter and all AC loads are turned off when connecting the inverter output lead wires to the loads.



Damage to the inverter will occur if an external AC power source is applied to the inverter's AC output.

- (a) Make sure the inverter is turned off when removing the inverter faceplate to access the field wiring compartment, see figure 2, item (e) on page 7.
- (b) Locate the set of 3 output wires labeled "AC Output": Black wire (Hot), White wire (Neutral) and Green wire (ground). See figure 8, page 17.
- (c) The AC hardwire output is not GFCI protected. GFCI outlets should be installed at all appropriate locations per NEC 551. External GFCI outlets should be Leviton GFCI #6599 or #8899 (15A).
- (d) The AC output should be wired to a listed 30 amps breaker in a distribution panel using 10-gauge wire.
- (e) All remote AC outlets should be mounted at a convenient location in UL listed outlet boxes.

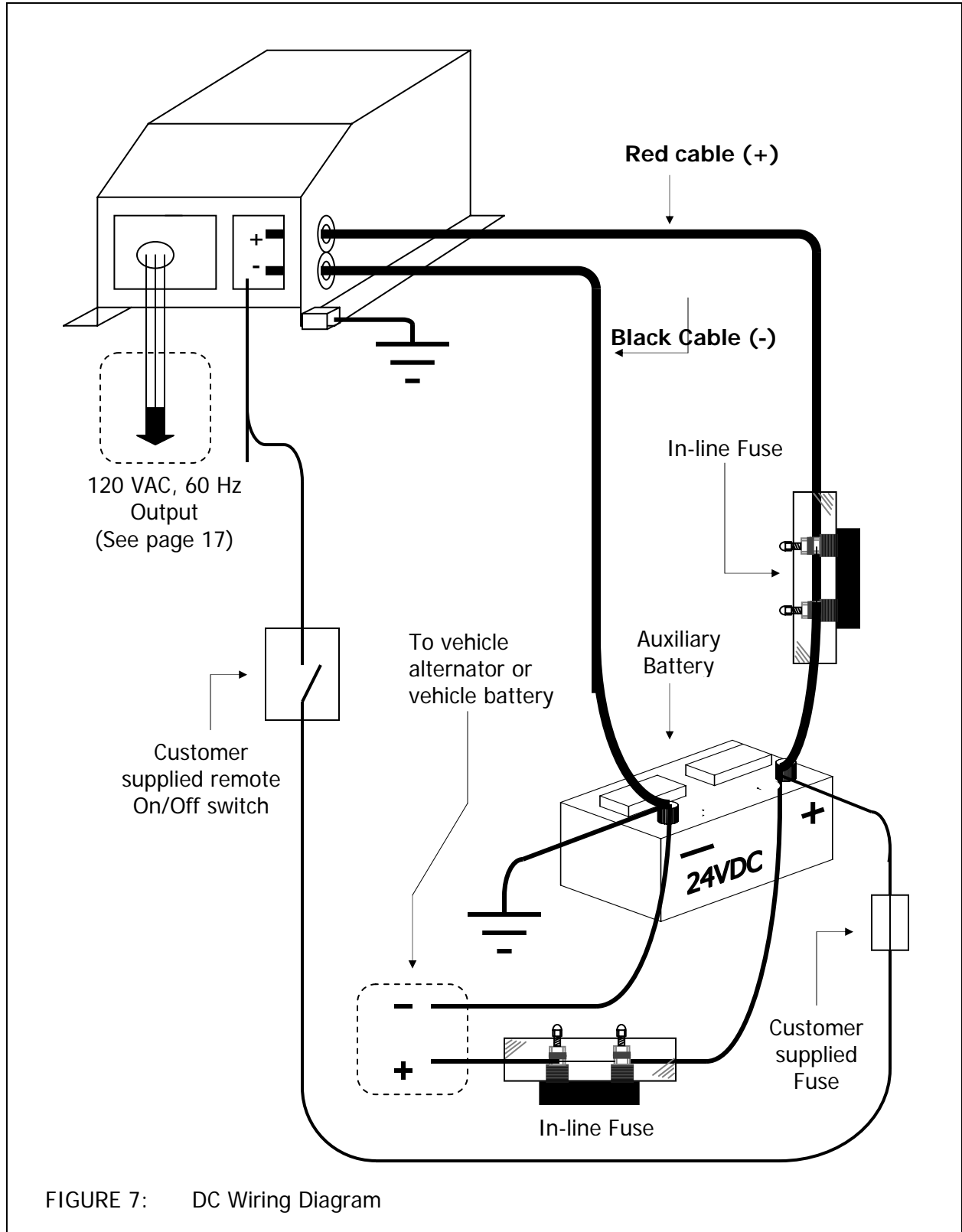

FIGURE 7: DC Wiring Diagram

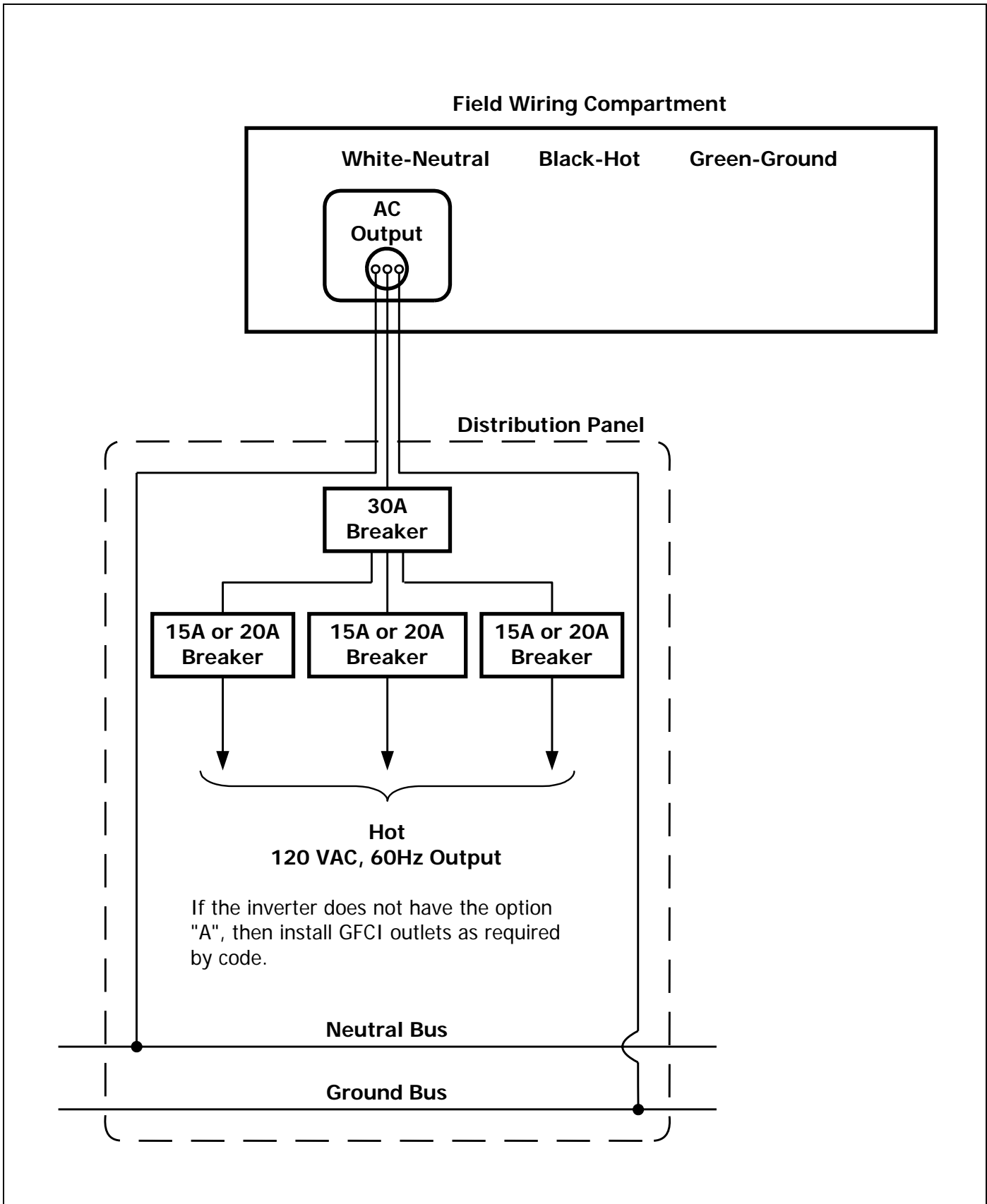

FIGURE 8: AC wiring diagram

4.1 Startup

4.1.1 General: After successful installation to operate the inverter do the following:

- (a) Switch the inverter front panel switch to ON. The Green LED "Inverter Power" will come on.
- (b) If the optional customer supplied remote switch is used, the inverter is switched ON or OFF by the remote switch. The inverte front panel switch and the remote switch are in series. See page 15, section 3.3.4
- (c) Turn the switch to OFF when the inverter is not in use. There is a 1 to 2 amps draw on the batteries from the inverter even when it is on, and there are no AC loads connected to the inverter.

Call Customer Service Department for free phone consultation during business (central time zone) hours at: 1-800-553-6418 or 1-651-653-7000; fax number 1-651-653-7600; e-mail: inverterinfo@sensata.com

5.1 Inverter Troubleshooting:

5.1.1 Important Notes:



Since the inverter has a quasi-sine waveform a TRUE RMS voltmeter is required for accurate AC voltage readings. Other voltmeters that use averaging circuitry will give an incorrect reading.

5.1.2 The Red LED Warning Indicators: There are three Red LED lights; they are Low battery, Overload and High temperature.

5.1.3 Inverter Troubleshooting Procedure:

- a) Check that all the circuit breakers are reset, including the one on the front of the inverter, see section 2.1.1 items (b) and (c), page 7.
- b) Connect a 100-watt light bulb to the GFCI receptacle on the front of the inverter.
- c) Set the inverter "On/Off" switch to **ON** and also the remote switch, if used.
- d) Check the connection to the remote switch, if used, to ensure that +24 VDC is present at the violet wire at the wiring compartment.
- e) Observe the LEDs light coming on at front control panel. Follow the troubleshooting chart on section 5.2, page 20.

5.2 Red LED Troubleshooting Messages

| LED Light | PROBLEM | POSSIBLE CAUSE |
|----------------------|--------------------------------------------------------------------------------------------------------------------------------------------------------|--------------------------------------------------------------------------------------------------------------------------------------------------------------------------------------------------------------------------------------------------|
| 1 No LEDs | The inverter is not connected to the batteries or the battery voltage is below 20 volts DC or fault in the inverter remote On/Off circuit. | Check the in-line fuses for continuity. Make sure the DC wires are clean and tight. Check the DC voltage at the inverter DC input. Check the connection to the remote switch; +24VDC must be present at the violet wire for the unit to operate. |
| 2 Low battery | Indicates that the inverter has shut off due to a low battery voltage condition. | Fault in the battery wiring, battery capacity and voltage or the in-line fuse. The inverter must be turned off to reset the circuit. |
| 3 Overload | Indicates that the inverter has shut off due to an overload condition. | Output wiring or load that is shorted, loads that exceed the inverter rating or an internal fault. The inverter must be turned off to reset the circuit. If the condition persists, call Sensata Technologies. |
| 4 High temp. | Indicates that the inverter has shut off due to high internal temperature. The unit will automatically turn back on when it has cooled to 40°C (104°F) | Verify that the inverter is in a vented compartment and that the fan is not blocked. High ambient temperatures combined with poor ventilation may also contribute to the shutdown. |

APPENDIX

Section 6

Chart A: Wire Gauge Recommendations

DC input wire gauge guide for 5% maximum DC voltage drop at full inverter output.

| Inverter Model | Full Load (Amps) | Peak (Amps) | Wire length from inverter to battery | | |
|----------------|------------------|-------------|--------------------------------------|-----------|-----------|
| | | | 1' – 10' | 11' – 15' | 16' – 20' |
| 24X26UVQ | 130 | 540 | 2 Ga. | 2 Ga. | 1 Ga. |

NR: Not Recommended

Note 1: Wire gauge is based on 135°C insulation; for lower temperature rated insulation and/or applications inside engine spaces use next larger gauge.

Note 2: These wire gauge recommendations are minimum. For large motor loads and other applications with high inrush currents, use a wire gauge 1 to 2 sizes larger than shown and keep the wire runs between the battery and SPS as short as possible. Make quality connections and use heavy gauge AC wiring to the loads.

Chart B: Fusing Recommendations

Note: Determine wire gauge from chart A, and then select the fuse from the table below. Use Bussmann fuse type ANN-XXX (where XXX is the ampere rating of the fuse)

| Wire Gauge | 8 | 6 | 4 | 2 | 1 | 1/0 | 2/0 | 3/0 | 4/0 |
|------------|----------|----------|----------|----------|----------|----------|----------|----------|----------|
| Fuse Size | 100 Amps | 150 Amps | 200 Amps | 250 Amps | 300 Amps | 350 Amps | 400 Amps | 500 Amps | 600 Amps |

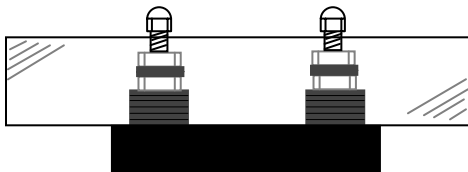

Fuse holder and cover



Fuse

Chart C: Charging cables & fusing guide

| Alternator | OEM | OEM Upgrades | | | |
|----------------|----------|--------------|----------|----------|------------|
| Current Output | 100 Amps | 130 Amps | 160 Amps | 200 Amps | 200 Amps + |
| Wire Gauge | 2 | 2 | 2 | 1/0 | 2/0 |
| Fuse Size | 250 Amps | 250 Amps | 250 Amps | 350 Amps | 400 Amps |

Note: If paralleling two alternators, add individual output currents.

Chart D: Industrial Electrical Product Wattage Ratings

| Product | Watts (Full load) | 120 VAC Amps. | Inverter Model | |
|-----------------------------------------------------------|----------------------|------------------|-------------------------|------------|
| Air Compressor, 1 HP | 2000 | 16 | 12X30U | Quasi-sine |
| Air Compressor, 3/4 HP | 1500 | 12.5 | 12X25U | Quasi-sine |
| Air Cond, 9,000 BTU | 1100 | 9.2 | 12X16U | Quasi-sine |
| Air Cond, 13,500 BTU | 1620 | 13.5 | 12X20U | Quasi-sine |
| Air Cond, 16,000 BTU | 1800 | 15 | 12X25U | Quasi-sine |
| Air Cond, 18,000 BTU | 2200 | 18.3 | 12X30U | Quasi-sine |
| Bucket (Basket) Heater | 1500 | 12.5 | 12X16U | Quasi-sine |
| Cable TV 90 Volt Power Supply | 2000 | 16.7 | 12/2400N | Pure sine |
| Computer, Laptop | 100 | .83 | 12/400N | Pure sine |
| Drill, Large | 1500 | 12.5 | 12X25U | Quasi-sine |
| Drill, Medium 1/2" | 750 | 6.3 | 12/1200 | Quasi-sine |
| Drill, Small 3/8" | 250 | 2.1 | 12/600 | Quasi-sine |
| Engine Block Heater | 750 | 6.3 | 12/1200 | Quasi-sine |
| Grinder | 1500 | 12.5 | 12X25U | Quasi-sine |
| Hammer drill, light duty (Hilti TE-504, TE-74, Te-704) | 1050 | 10.5 | 12X16U | Quasi-sine |
| Hammer drill, medium duty (Hilti TE-804, TE-805) | 1350 | 12.5 | 12X20U | Quasi-sine |
| Hammer drill, med./heavy duty (Hilti TE-905) | 1600 | 14 | 12X25U | Quasi-sine |
| Impact Wrench | 900 | 7.5 | 12X20U | Quasi-sine |
| Personal Computer | 350 | 2.9 | 12/600 | Quasi-sine |
| Pipe Threader | 1800 | 15 | 12X25U | Quasi-sine |
| Plastic Pipe Electro-fusion up to 8" | 3900 | 32.5 | 12/3600N | Pure sine |
| Plastic Pipe Fusion Irons | 2400 | 20 | 12X30U | Quasi-sine |
| Prover, gas meter | | | 12/3000N | Pure sine |
| Recharger, battery operated tool | 240 | 2 | 12/400N | Pure sine |
| Saws-All | 720 | 6.0 | 12/1200 | Quasi-sine |
| Sewer camera w/lights | | | 12/1200N | Pure Sine |
| Sewer camera w/lights & crawler | | | 12/1800N to 12/3000N | Pure Sine |
| Space Heater | 1500 | 12.5 | 12X20U | Quasi-sine |
| Sump Pump, 1/2 HP | 1000 | 8.3 | 12X20U | Quasi-sine |
| Thumper (electrical fault locator) | 2500 | 20.8 | 12/3000N | Pure Sine |
| TV, Color, 19" | 200 | 1.7 | 12/300 | Quasi-sine |
| VCR | 25 | 0.2 | 12/130 | Quasi-sine |
| Water Pump, Small | 1000 | 8.3 | 12X20U | Quasi-sine |
| Window Fan | 200 | 1.7 | 12/300 | Quasi-sine |

Notes:

1. The power ratings listed above should be used for reference only.
2. To find the correct power consumption or "wattage", multiply the AC voltage times the amps listed on the product nameplate. In some cases, the wattage is listed on the nameplate also.
3. Make sure your inverter is large enough to supply the appropriate wattage to loads.
4. Find out if the loads you are running are pure sine wave form sensitive. The inverter output waveform is quasi-sine.

Chart E: Battery Configuration:

Batteries interconnect in two ways: Series or parallel.

- a) Series configuration: Increases voltage while keeping the Ampere Hour (AH) capacity constant. For example: Two deep cycle 12 Volt batteries @ 105 AH each connected in series, results in a total output of 24 Volts (12 Volts + 12 Volts) @ 105 AH
- b) Parallel configuration: Increases capacity while keeping the voltage constant. For example: Two deep cycle batteries 12 Volt @ 105 AH each connected in parallel, results in a total output of 12 Volt @ 210 AH (105 AH + 105 AH).

Note: The amount of electrical energy in these two configurations is identical.

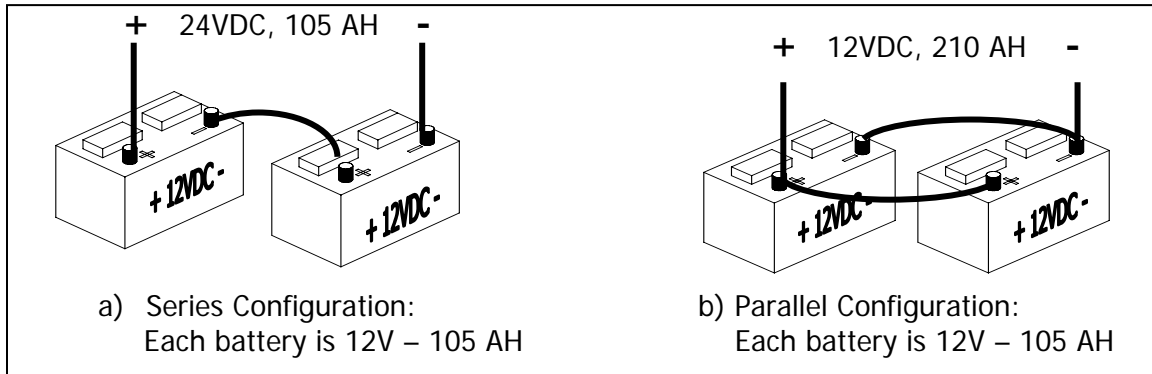

Chart F: Useful Formulas

Ohm's Law Voltage (Volts) = Current (Amps) x Resistance (Ohms)

Power (Watts) = Voltage (Volts) x Current (Amps)

Chart G: Sizing the Battery Bank

The first step is to estimate the total watts of load and how long the load is to operate. Look at the input electrical nameplate for each appliance (see chart D, page 22) and adding up the total requirement can determine the total load wattage. Some loads are not constant, so estimations must be made. An example is a full-size refrigerator (750 watt compressor) running 1/3 of the time would be 250 watts per hour. Also, the amount of time these loads are to operate from the inverter must be decided.

After the load and running time are decided, the battery bank size can be calculated. For a 24-volt inverter system, each 100 watts of load on the inverter requires 5 amps DC from the battery, a 20 to 1 ratio.

An example of this calculation is:

1. Total = 1000 watts per hour
2. Watts from 24 volt battery = $1000 / 20 = 50$ AH

Next the number of ampere hours (AH) must be multiplied by the time in hours that the load is to operate. For example, the load is to operate 3 hours:

For a 24 volt system: 50 amps DC x 3 hours = 150 amp hour (AH).

During periods of heavy DC current draw, less than 100% of stored battery energy is usable. A safe assumption is 50% usable energy. Therefore, to provide 150 AH of usable energy a 300 AH capacity battery bank is required.

Chart H: Waveform Discussion

Pure sine waveform electrical power is the world's standard waveform for the electrical utility grid (see figure a below). This waveform is the naturally occurring waveform that is emitted from a rotating electrical generator, so it was a logical decision to make this the standard. This is commonly called alternating current or AC.

The other common type of electricity is direct current or DC, which is emitted from batteries. A limited number of electrical products will operate from DC versus a large number from AC. Inverters are devices that convert DC to AC electronically, or statically, without the use of a rotating generator.

It is very difficult to produce a pure sine waveform electronically. The original inverters produced a square waveform output that was cheaper and easier to produce. These inverters are very limited in the equipment they will operate and are typically used for resistive AC loads. They cannot be U.L. listed.

Newer inverters output a more usable waveform called quasi-sine waveform by Underwriters Laboratory U.L. (see figure b below). Other names for this waveform are modified sine wave, rectangular wave, or modified square wave. A correct version of this quasi-sine waveform can be granted U.L. approval. This waveform can operate most equipment and will not harm other U.L. listed equipment.

The newest inverters output pure sine waveforms (Figure a). These inverters will operate any load within their power rating range, but usually do not have the motor starting capability of quasi-sine inverters. There are several electrical products that require a pure sine waveform to operate correctly. A partial list of them is provided below. See chart D on page 22 also.

- Microprocessor controlled tools and equipment
- Phase controlled devices such as ceiling fan speed controls, incandescent lamp dimmers, and power supplies.
- Transformless capacitive powered devices such as DC tool battery chargers, compact fluorescent light, and smoke detectors.

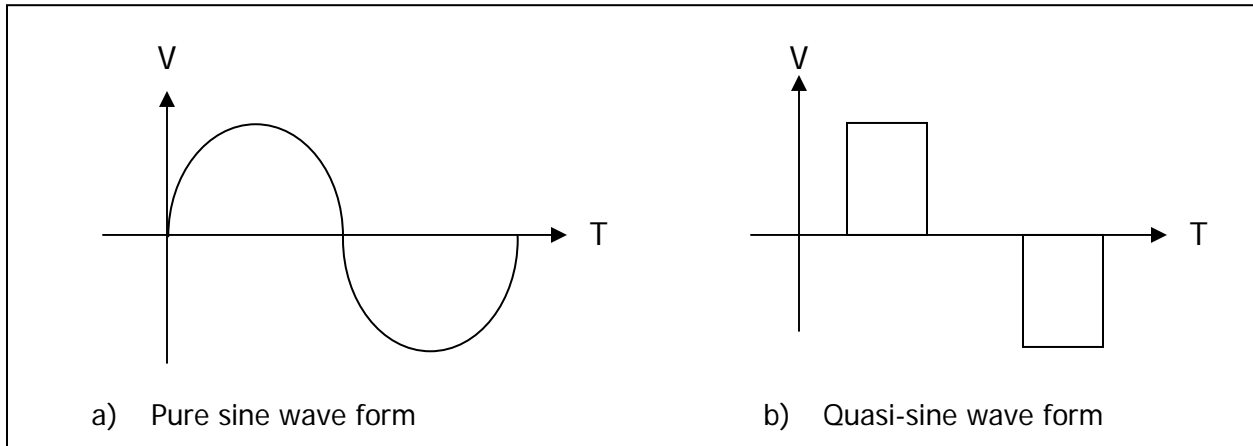

GLOSSARY

Section 7

AGM: (Absorbent Glass Mat) A lead-acid battery that incorporates a sponge glass mat separator to immobilize the electrolyte. Because of the immobilized electrolyte, AGM batteries will not leak or spill.

Alternating Current: Pulsating electric energy in which the direction of the electron flow is rapidly changed, so the end terminal becomes in rapid succession electrically positive, then negative. Abbreviated AC.

Alternator: Alternating current generators (alternators) produce alternating current that is "rectified" (converted into direct current) before it can be used in an automobile.

Ampere: The unit of electrical current equal to the steady state current produced by one volt applied across a resistance of one ohm, abbreviated Amps.

Ampere Hour: A measure of the quantity of electricity, being one ampere for one hour. It is used to express battery capacity. It is obtained by multiplying the current in amperes by the length of time that the current is flowing, abbreviated AH.

Current: The time rate of flow of electricity, normally expressed as amperes, like the flow of a stream of water.

Deep Cycle Batteries: Batteries that are designed to withstand repetitive discharge/recharge cycles and continue to provide their rated capacity.

Direct Current: A one-direction electron flow. Abbreviated DC.

Discharge: Conversion of a battery's chemical energy into electrical energy.

Electricity: The flow of electrons through conductive materials and devices.

Flooded: Describes a type of lead-acid battery filled with liquid electrolyte and vented to the atmosphere.

Fuse: A component of a circuit placed in series and designed to melt "open" at a specific level of current. Fuses protect wires from overheating.

Gassing: Bubbles from gases being released at one or more of the electrodes during electrolysis.

Gel Cell Battery: A lead-acid battery in which the electrolyte is immobilized by adding a gelling agent. This battery has the advantage of being non-spillable. A gel cell battery is totally sealed, valve regulated, with no possible access to the cells.

Hydrometer: A device used to measure density or specific gravity of electrolyte solutions.

Lead-Acid Battery: A storage battery using lead (Pb) and lead peroxide (PbO₂) as the "active" materials and an electrolyte solution of water and sulfuric acid (H₂SO₄). A storage battery changes chemical energy into electricity.

Ohm: A unit of electrical resistance.

Ohm's Law: An equation that expresses the relationship between voltage, current and resistance in an electrical circuit.

The equation can be expressed as follows: Volts (V) = Amps (I) X Ohms (R).

Ohmmeter: An instrument used to measure resistance in an electrical circuit.

Open Circuit Voltage: The voltage at a battery terminal when no appreciable current is flowing.

Polarity: The quality of an object characterized by two opposite charges, as in the positive and negative poles of a battery.

Pure sine wave: World's standard waveform for the electrical utility grid. This waveform is the naturally occurring waveform that is emitted from a rotating electrical generator.

Quasi-sine wave: An electronically generated waveform that looks like a modified square waveform. It is also called a rectangular waveform.

Resistance: The opposition of a conductor to the passage of an electrical current, usually expressed in ohms.

Specific Gravity (S. G.): The specific gravity of battery electrolyte is the weight of the electrolyte compared to the weight of an equal volume of distilled water.

State of Charge: The amount of electrochemical energy left in a battery.

Volt: The unit of measurement of electromotive force. The force required to send a current of one ampere through a conductor with a resistance of one ohm.

Voltmeter: The meter used to measure the amount of voltage in a circuit.

Watt: The unit of measurement for electrical power. The algebraic symbol is "W".

Waveform stabilizer: A circuit designed to absorb reflected power from a reactive load, such as motors.

LIMITED WARRANTY

Section 8

SHIPPING TERMS: F.O.B. St. Paul Minnesota. Freight prepaid and billed, subject to prior credit approval.

MINIMUM ORDER: \$50.00 Net Price

LOSS OR DAMAGE: Loss or damage in transit are the responsibility of the carrier. Any claim should be filed with the delivering transport company. Invoice, Bill of Lading and Delivery receipt with damage noted therein must accompany any claims for freight damage. Claims for shortage and lost shipments must be made in writing to Sensata Technologies, Power Controls White Bear, St. Paul, MN within 10 days of date of shipment. Claims not reported within this time frame will not be honored.

PRICES: Prices are subject to change without notice. All orders are subject to acceptance at the factory. We reserve the right to invoice prices in effect at time of shipment.

TERMS: Net 30 days with approved credit, credit card or C.O.D.

RETURN GOODS POLICY:

- No returned materials will be accepted without an accompanying Returned Materials Authorization Number (RMA) from the factory.
- Credit will be issued for returned goods to the original purchaser within 60 days of purchase, provided the inverter is returned to Sensata unused and not mounted. The amount of credit will be issued at Sensata's discretion based on the condition of the product.
- Customer must be in good standing with Sensata Technologies.
- Inverters that are discontinued, high-voltage (over 24vdc), special-order or used are excluded and will not be eligible for credit. Non-inverter items such as cable assemblies, fuses and fuse holders, will not be eligible for credit
- Support components supplied by Sensata vendors will be covered under that manufacturer's credit return policy.
- Customer pays return freight.

PLEASE SHIP AUTHORIZED RETURNS TO:

Sensata Technologies | Power Controls White Bear | 4467 White Bear Parkway | St. Paul, MN 55110
Return Freight Prepaid

LIMITED WARRANTY:

Sensata Technologies extends the following warranty to the original purchaser of those goods subject to the qualifications indicated. Sensata warrants to the original purchaser for use that the goods or any component thereof manufactured by Sensata will be free from defects in workmanship from the date of purchase for the period listed on the product label, provided such goods are installed, maintained and used in accordance with Sensata and the original manufacturer's written instructions. Damages caused by the misuse, undue care or obvious wear through use will not be covered by this warranty.

Components not manufactured by Sensata, but used within the assembly provided by Sensata, are subject to the warranty period as specified by the individual manufacturer of said component, provided such goods are installed, maintained and used in accordance with Sensata and the manufacturer's written instructions.

Sensata's sole liability and the Purchaser's sole remedy for a failure of goods under this limited warranty and for any and all claims arising out of the purchase and use of the goods, shall be limited to the repair or replacement of the goods that do not conform to this warranty.

To obtain repair or replacement service under the limited warranty, the purchaser must contact the factory for a Return Material Authorization (RMA). Once obtained, send the Return Material Authorization Number along with the defective part or goods to:
Sensata Technologies, Power Controls White Bear, 4467 White Bear Parkway, St. Paul, MN 55110. Return Freight Prepaid.
THERE ARE NO EXPRESS WARRANTIES COVERING THESE GOODS OTHER THAN AS SET FORTH ABOVE. THE IMPLIED WARRANTIES OF MERCHANTABILITY AND FITNESS FOR A PARTICULAR PURPOSE ARE LIMITED IN DURATION TO ONE YEAR FROM DATE OF PURCHASE.

SENSATA TECHNOLOGIES ASSUMES NO LIABILITY IN CONNECTION WITH THE INSTALLATION OR USE OF THE PRODUCT, EXCEPT AS STATED IN THIS LIMITED WARRANTY. SENSATA TECHNOLOGIES WILL IN NO EVENT BE LIABLE FOR INCIDENTAL OR CONSEQUENTIAL DAMAGES.

WARNING: LIMITATIONS ON USE: DIMENSIONS® brand products are not intended for use in connection with Life Support Systems and for Avionic use. Sensata Technologies makes no warranty or representation in connection with their products for such uses.