

# ME-AGS-N wiring diagram – For Westerbeke (8.0- 15.0 BTG Gas Generators)

Using two external relays for bilge air blower

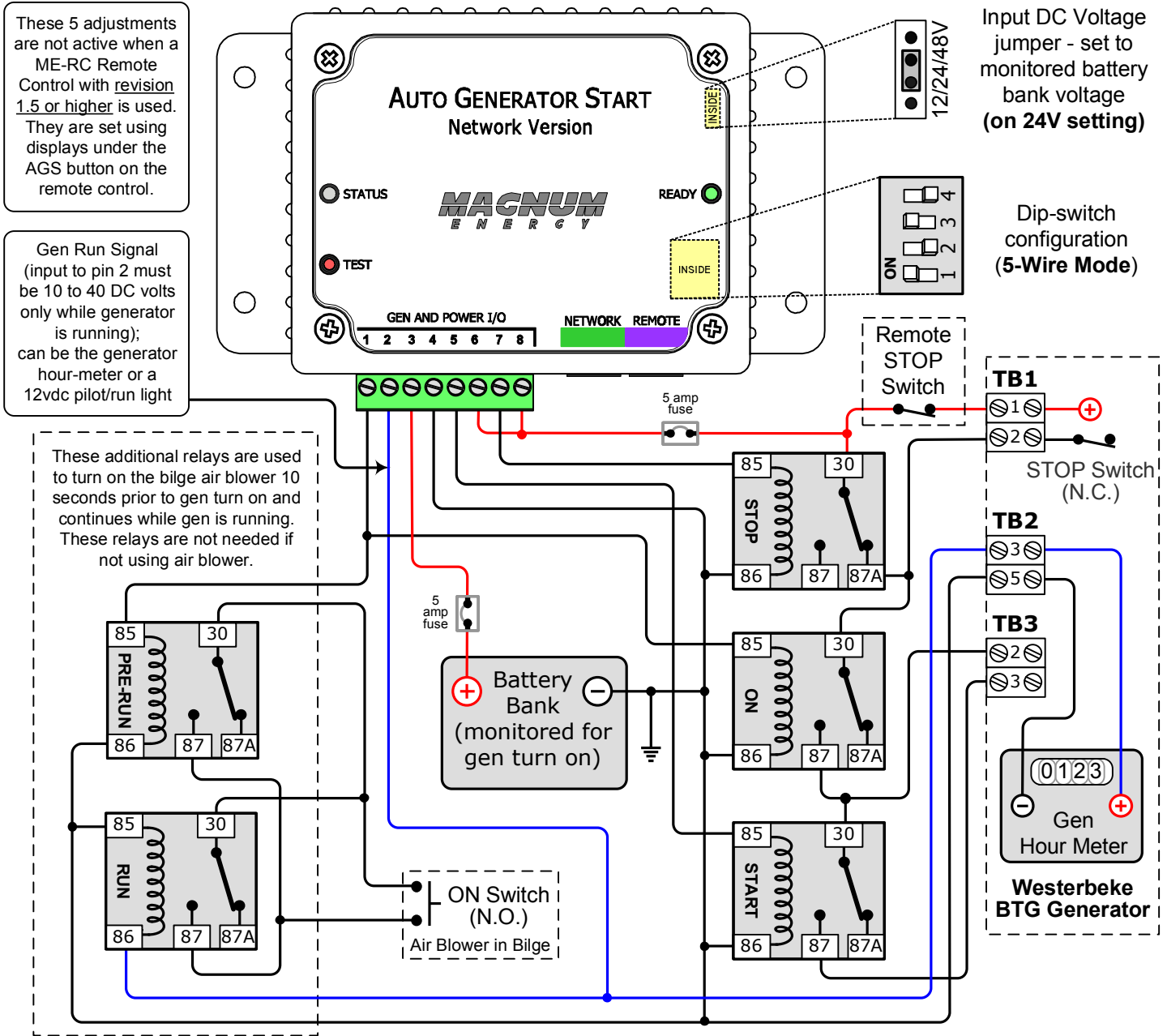

Relays used are SPDT 30 Amp, 12 VDC coil relays [shown in the non-energized (N.C.) position]

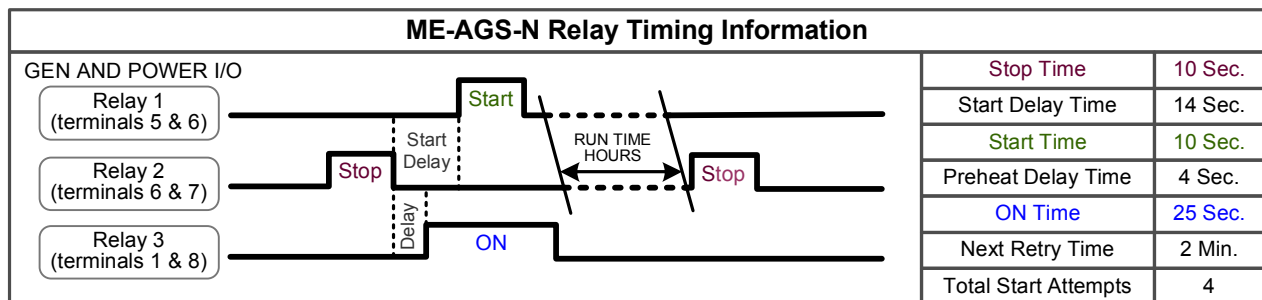

Magnum Energy, Inc. provides this diagram to assist in the installation of the Auto-Generator Start controller. Since the use of this diagram and the conditions or methods of installation, operation and use are beyond the control of Magnum Energy, Inc., we do not assume responsibility and expressly disclaim liability for loss, damage or expense arising out of the installation, operation and use of this unit.